



# PARASNATH ALUMINIUM

THINK ALUMINIUM, THINK PARASNATH

THINK ALUMINIUM, THINK PARASNATH

Redg. Office: "Ajit Mansion" 10/1/1C Kalakar Street, 1st Floor, Kolkata-700007  
Factory Address: "Uttsav Park", Dulagarh, Village & P.O. Chaturbhuj Kathi, P.S  
- Sankrail, Para - Hudati Para, Plot No. 55 Phase - 1, Howrah - 711303

[parasnathaluminium.com](http://parasnathaluminium.com) | [info@parasnathaluminium.com](mailto:info@parasnathaluminium.com)  
+91 9836622666 / 8617263130 / +91 9331199929 / 9831640153

# ABOUT US

We are engaged in supplying a wide range of Scaffolding Systems and Scaffolding/Shuttering Components. Known for their high quality, durability, and wide utility

We, Parasnath Aluminium from 2005 are a Manufacturer, Wholesale trader and Distributor of a high-quality range of Aluminium and Steel Products.

Over the past years, Parasnath Aluminium the three times winner of the Export Excellency Awards from the Gov. of India has established itself as the leading organization in the field of high-quality Scaffolding & Formwork systems for the construction & maintenance industry in India and also as a major exporter. Through a network of Joint-Venture Companies and subsidiaries, it is now spread over a lot of parts of the world. Parasnath's Aluminium reputation has been built up steadily over the years by putting the needs of its customers above every other consideration. Everything we do is designed to help our customers achieve maximum on-site efficiency without compromising safety standards.

The success of any construction project depends on how closely you stick to planned time schedules and cost estimates. When you purchase scaffolding or formwork equipment from Parasnath, you can draw the resources of a well-spread service organization.

Regardless of the specific type of equipment and site location, we will work with you to ensure your project runs according to plan.

The extensive design and manufacturing resources of Parasnath give us the ability to develop or adapt products quickly to suit the constantly changing needs of our customers.

## PURPOSE

***We exist on this planet to provide safe access to workers at heights, give safe support and desired shapes to the structures by providing molds.***

## CORE VALUE

- ***GoGreen***
- ***Sustainability***
- ***Reliability***
- ***Techno-care***

- CUPLOK's unique locking action makes it the fastest, safest, most economical & widely used scaffolding system in the world.
- The success of CUPLOK lies in the 'node point' or fastening method. Four horizontals can be fastened at one time, making a very rigid connection. The horizontals bear directly onto the verticals and are firmly clamped by the action of the top cup.
- There are no loose parts to lose. CUPLOK is made from the highest quality steel providing great strength while being light and easy to handle.
- When investing in equipment, it must be as versatile as possible, and PA CUPLOK is ideal for many applications: formwork, support, general access, circular scaffolding, mobile towers, loading towers, and many other uses.
- CUPLOK is now widely used in industries as diverse as shipbuilding, power plant, refinery maintenance, and conservation of monuments.
- Speed of erection and simplicity are the keys to CUPLOK's success. Designed to be tough, CUPLOK is highly resistant to damage.
- PA CUPLOK will provide you with important cost savings as a result of its speed of erection. It can be erected by unskilled labor, easily stored & maintained, and used in various applications.

## CUPLOCK COMPONENTS

### VERTICALS / STANDARDS

CUPLOK Verticals, made out of 40 mm NB tubes, are available to suit any propping or access application economically. The Verticals can be used for support or access as required. The connection point is set at 500/1000 mm vertical intervals for maximum versatility in use. The lower cups are welded in position the upper moveable, caps are retained by a fixed stop. The Verticals are drilled for the fixing of the spigot joint. A bolt can be used to restrain upward forces if required.

**Available in following sizes:**

3000mm 2500mm 2000mm  
1500mm 1000mm 500mm

### HORIZONTALS / LEDGERS

CUPLOK Horizontals, made out of 40 mm NB tubes, are available in a range of standard sizes or can be made to a special length if required. The forged blade end fits in the cup of the Vertical. The simple robust design ensures that Horizontals need no maintenance.

**Available in following sizes:**

3000mm 2500mm 2000mm  
1500mm 1000mm 500mm

### ACCESS SCAFFOLD LADDER

A simple latch-on MS Ladder suitable for scaffold height of 10-12 meters

**Available in the following sizes:**

2000mm 1500mm

### OMEGA HOP-UP BRACKETS

The 1-board, 2-board and 3-board Hop-Up Brackets incorporate the Omega section for locating scaffold boards and attaching to the cup joint so that the Hop-Up Brackets are correctly located, each unit includes a CUPLOK joint to accept Horizontals

### FIXED BASE/HEAD PLATE

This component is used either as a base plate at the bottom of a jack to give the necessary spread of load, or when the jack is used at the top of the Vertical as a head plate to accept a Drop Head

### SPIGOT

When necessary, Verticals are connected end to end by an internal Spigot. This is bolted to the Vertical

### TOE BOARD

Available in different sizes suitable for working platform of various length and width

### CASTOR WHEELS

Cuplok casters lock on to the bottom of Verticals. The 200 mm diameter wheels provide for easy movement of mobile scaffolds

### CANTILEVER FRAMES

At the edges of a building, it is often necessary for economy speed of working and safety to provide support beyond the edge. The Cantilever frame fits directly to the Vertical at the node points. The frame accepts universal jacks for carrying all types of support forkheads, dropheads, etc. This item is invaluable for supporting slab edge formwork. Frames the blade ends for locating in the top joints and accepting lack in position

**Available in the following sizes:**

1500 mm x 1500 mm  
1500 mm x 1000mm  
1200mm x 1500 mm  
1200 mm x 1000mm

### OMEGA TRANSOM/HORIZONTAL

Omega transom which replaces the tubular horizontals offers a firm location for scaffold boards that are fixed on these specially designed Omega sections thus providing a flat and level decking

### ADI BASEPLATE/STIRRUP HEAD

The Adj, base plate's stirrup heads provide a method of adjustment that can be used at either the top or bottom of a scaffold support structure. It is used in conjunction with Forkheads and Adaptors and can accept the full loading capability of Cuplok when fully braced

Range: 45mm to 850mm Ad, comprising various sizes.

### STEEL SCAFFOLD BOARDS

A range of sizes with the non-slip working surface is used with/without the Omega Horizontals to form the lightest of all working platforms.

**Available with hooks/without hooks in the following width:**

300mm 250mm 200mm 100mm

# ACCESS SCAFFOLDING

## PA CUPLOK SYSTEM

The leading scaffolding management worldwide, CUPLOK's unique node point connection makes it the fastest, safest and most versatile scaffolding ever designed

CUPLOK standards are manufactured from higher-grade steel tubes. The connection point is set at 500/1000 mm. The captive mobile cups are made out of malleable Cast iron to ensure rough sea handling and welded bottom cups are pressed from high-quality steel. Loose spigots are used to provide trouble free and a stronger connection between verticals

All ledgers Horizontals have identical forged blade ends to fit in the cups of the standards

## ACCESSORIES:

- Adjustable Jack Suitable for providing an adjustment from 75mm up to 850 mm at the top/base
- Cantilever A' Frame Provides additional access for support. Also used for cantilever scaffolding
- Other accessories Beam Bracket Bridging Horizontal Hop-up Bracket/Omega Transom etc.

## FEATURES

- Cup Joint Gives rigid connection between vertical and
- Cup Action Faster erection allows 4 horizontals to be fixed or released in a single operation
- Fixing of top cup Only hammer required
- No small loose parts: Losses reduced
- Removable spigot: Gives greater Flexibility of use

---

## 'H' FRAME SYSTEM

Consists of welded frames with 48,3 mm OD verticals, traced together with scissor-type cross braces utilizing spring dips. Diagonal bracing is provided in alternate bays for scaffold heights up to 20 meters and in all bays for greater heights. Frame with 60.3 mm OD Verticals are available for the staging of heavier structures

Standard Sizes 'H' Frame-2000 x 1250, 1500x1250, 1000x 1250mm.

Cross Braces Suitable for frame spacing of 25,20, 15, and 10m her sizes are made available on request.

## A.P.U. SYSTEM

Consists of two verticals and one horizontal, both of 48.3 mm OD tube Or verticals Lugs welded at 500 mm centers provide rigid support to horizontal which has built in three way clamps welded at both ends to take bracing tube connecting units

Standard sizes-2000 x1220, 1500 x 1220, 1000x 1220, 2000x 1830 1500 x 1630.

## WEDGELOCK SYSTEM

Consists of verticals with wedge housing welded at every 500mm and horizontals with captive wedges welded both 48.3 mm OD tubes. A good scaffolding system for repair and construction jobs, where speed and versatility are important Accessories Angular Transom Hop-up Bracket etc.

## PA SCAFFOLDING AS SUPPORT STAGING

CUPLOK, H Frame and A.P.U scaffolding detailed above are suitable for use as support staging for Structures etc BSI. can provide technical guidance in providing a safe and optimal design of staging for any type of structure. Further, it is recommended that staging is always erected on sound footing timber sleepers etc for proper distribution of load to ground and ensure that all verticals are in plumb

## PA SCAFFOLDING FOR INDUSTRIAL MAINTENANCE

BSI Scaffolding Equipment, in particular CUPLOK, is ideally suited for maintenance and repair works in various industries like shipbuilding and repairs, Oil/Petrochemical, Offshore and Power projects including Boiler Maintenance

---

## SCAFFOLD ACCESSORIES:

Fond Base Pare for 453mm CD Tubes or for 60.3 mm OD tubes with Pins/Spigot

## ACCESS SCAFFOLD LADDER

A simple latch-on MS Ladders suitable for scaffold height of 10-12 meters Available in the following sizes: 2000mm, 1500 mm

## TOE BOARD/GUARD

Available in different sizes suitable for working platform of various lengths and widths

## ADJ. BASE PLATE STIRRUP HEAD

The Adj base plate stirrup beads provide a method of adjustment that can be used at either the top or bottom of a scaffold support structure. It is used in conjunction with Forkheads and Adaptors and can accept the full loading capability of PA Cuplock when fully braced Range 45mm to 850mm Ad comprising various sizes

## OTHER PA SCAFFOLD ACCESSORIES

- Access Bracket
- Staircase Coupler along with staircase treads & risers
- Castor Wheel
- Safety Equipment
- Fixed modular staircase
- Scaffold Board/Jallis

# PA CUP LOCK SYSTEM

## VERTICAL STANDARD (OPEN END)

Made from a 48.3mm diameter x 3mm thick high-grade iron tube, PA Lock System Standards (Vertical) is formed by two cups a fixed bottom cup which is welded to the Standard (Vertical) at pre-located intervals i.e. 500mm and a sliding top cup. The forged blade ends of the Ledger (Horizontal) are located in the bottom cup. The top cup is moved down and rotated to secure the components in place and tightened by a hammer blow to give a positive and rigid connection

CODE	SIZE (mm)	WEIGHT (KG)
		PAINTED
MSV500S	500	2.30
MSV1000S	1000	4.50
MSV1500S	1500	6.60
MSV2000S	2000	8.90
MSV2500S	2500	11.20
MSV3000S	3000	13.30

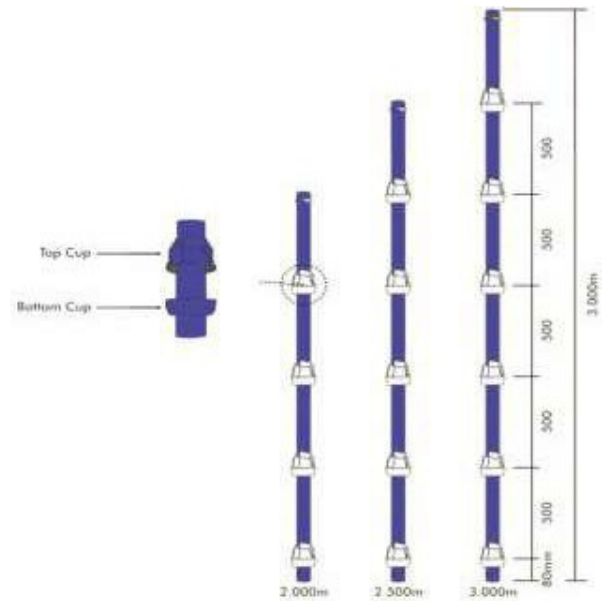

## LEDGER BLAD - CLOSED

CODE	SIZE (mm)	WEIGHT (KG)
		PAINTED
MSL500BS	500	2.30
MSL900BS	900	4.50
MSL1000BS	1200	6.60
MSL1200BS	1500	8.90
MSL1500BS	1800	11.20
MSL1800BS	2000	13.30
MSL2000BS		



## VERTICAL STANDARD (WITH SOCKET)

PA make Vertical with Socket Made from 48.3mm diameter x 3mm thick high-grade iron tube, PA Lock System Standards (Vertical) is formed by two cups a fixed bottom cup which is welded to the Standard (Vertical) at pre-located intervals i.e. 500mm and sliding top cup. This vertical will not require any extra spigot for the connection.

CODE	SIZE (mm)	WEIGHT (KG)
		PAINTED
MSV500S	500	2.30
MSV1000S	1000	4.50
MSV1500S	2000	6.60
MSV2000S	2500	8.90
MSV2500S	3000	11.20
MSV3000S		13.30



## JOINT PIN

CODE	SIZE (mm)	WEIGHT (KG)
		PAINTED
MSV2500S	2500	11.20
MSV3000S	3000	13.30



# PA RING LOCK SYSTEM

## RINGLOCK NODE CONNECTION

Ring lock node connection consists of standards with rosettes every 0.5m and adaptive horizontal members with a cast end wedge (Ledger/Transom). When connected the ledger ends and rosettes create a very strong connection. It is this connection that transmits forces throughout the scaffold structure.

The Ring lock rosette has been manufactured to have 8 holes, 4 of which are small and 4 are large. The smaller holes represent the 90-degree angle at which Ledgers / Transoms are fitted. The larger holes accommodate the diagonal bay braces and ledgers at variable angles.

The rosette also allows for the Ledgers to be connected into the larger holes which gives up to 15 degrees of maneuverability.



## TO MAKE A CONNECTION

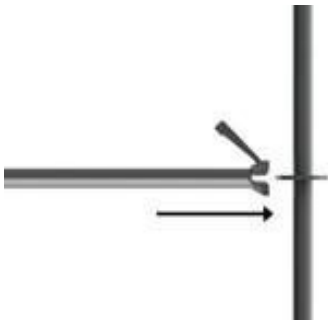

Slide Ledger head over the hole in the rosette that is to be used



Rotate wedge and insert through hole in rosette



Hammer home wedge to secure in place to create a strong and rigid connection

## STARTER/BASE COLLAR

The Starter/Base collar is the beginning vertical member of the Ringlock Scaffolding system. It sits upon a fixed or adjustable base.

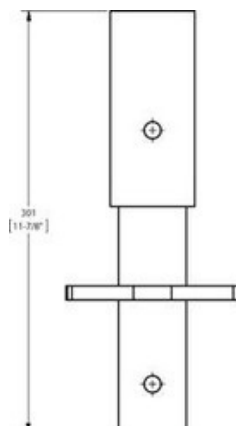

CODE	LENGTH (MM)	WEIGHT (KG) PAINTED
RBLC300	300	2.51

# STANDARD WITH CRIMPED SPIGOT

Standards are the vertical members of Ringlock scaffolding. The standard provides vertical support for scaffolding. The spigot is permanently fixed in place.

CODE	REFERENCE NO.	DESCRIPTION
MSRV500	500	3.32
MSRV1000	<del>1000</del> 1500	5.66
MSRV1500	2000	8.00
MSRV2000	2500	10.35
MSRV2500	3000	12.69
MSRV3000		15.03

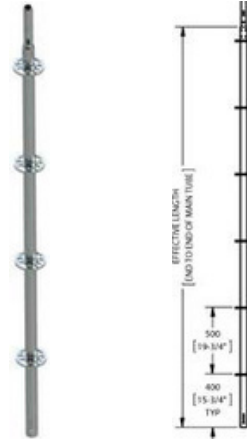

## RING LOCK LEDGERS



CODE	LENGTH (mm)	WEIGHT (KG)
		PAINTED
MSRL500	500	2.20
MSRL900	<del>900</del> 1200	3.80
MSRL1200	1500	4.50
MSRL1500	1800	5.50
MSRL1800		6.40

## DIAGONAL BRACE

CODE	LENGTH (mm)	WEIGHT (KG)
		PAINTED
MSRDB700	700	7.88
MSRDB1000	<del>1000</del> 1219	8.08
MSRDB1219	1500	8.30
MSRDB1500	1800	8.90
MSRDB1800	2000	9.30
MSRDB2000	2439	9.80
MSRDB2439	3000	10.44
MSRDB3000		11.82



## LEDGER O-TYPE



CODE	LENGTH (mm)	WEIGHT (KG)
		PAINTED
MSRLO500	500	3.12
MSRLO1000	<del>1000</del> 1200	4.70
MSRLO1200	1500	5.00
MSRLO1500	2000	6.36
MSRLO2000	2500	8.70
MSRLO2500		9.85

## MID TRANSOM O-TYPE

Mid Transoms are designed to create a transom at the deck level anywhere inside of the bay by straddling the outer ledgers/transoms of the bay.

CODE	REFERENCE NO.	DESCRIPTION
MSRV500	500	3.32
MSRV1000	1000	5.66
MSRV1500	1500	8.00
MSRV2000	2000	10.35
MSRV2500	2500	12.69
MSRV3000	3000	15.03

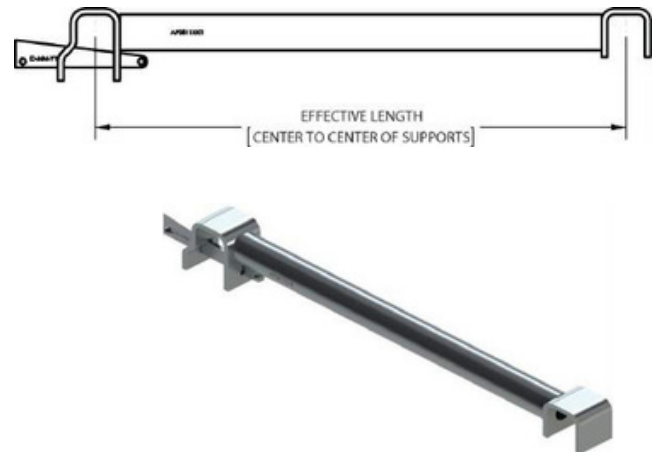

## DIAGONAL BAY BRACE RIGHT AND LEFT

Diagonal Bay Braces are used for the lateral bracing of Ring lock scaffolds. They can also be used as compression and tension members for cantilevers/spurs where they transmit loads back into the main scaffold structure. Diagonal/ Bay Braces are also used for handrails in the Ring lock Steel Stair System.

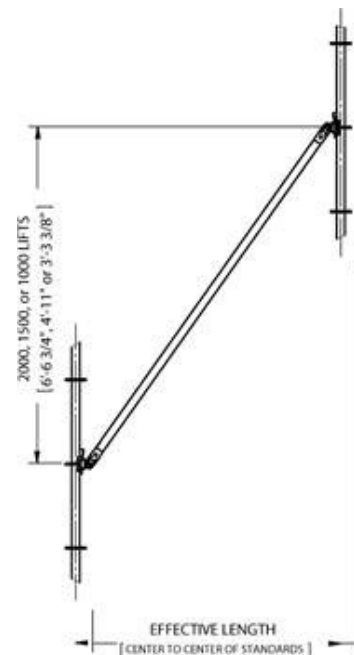

CODE	REFERENCE NO.	DESCRIPTION
MSRDB880	880	7.88
MSRDB1065	1065	8.08
MSRDB1150	1150	8.17
MSRDB1570	1570	8.79
MSRDB1820	1820	9.23
MSRDB2430	2430	10.44
MSRDB3050	3050	11.82

# SBSIPL KWIKSTAGE SYSTEM

## KWIKSTAGE SYSTEM

Kwikstage is one of the most universally established scaffolds throughout the world. Used for access and falsework applications, it's the inherent simplicity that makes Kwikstage a versatile, efficient, and cost-effective alternative to traditional loose props and tube & fitting scaffolds.

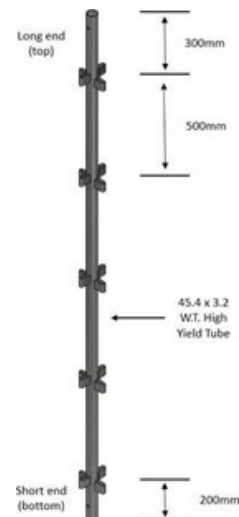
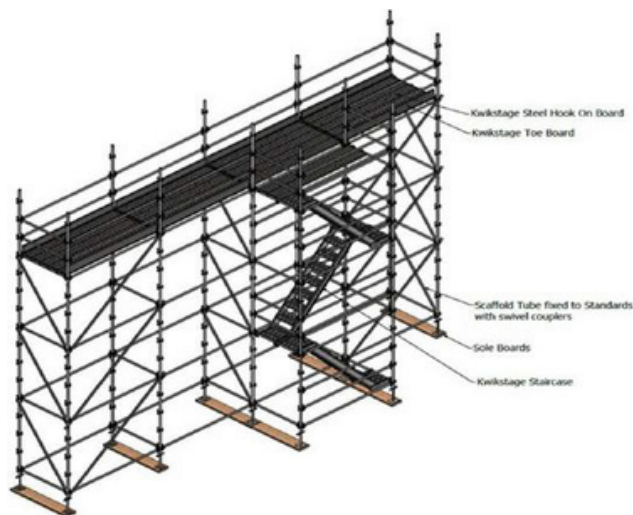

## KWIKSTAGE STANDARD

CODE	REFERENCE NO.	DESCRIPTION
MSKS500	500	2.50
MSKS1000	1000	4.90
MSKS1200	1500	5.20
MSKS1500	2000	7.40
MSKS2000	2500	9.80
MSKS2500	3000	12.30
MSKS3000		14.80

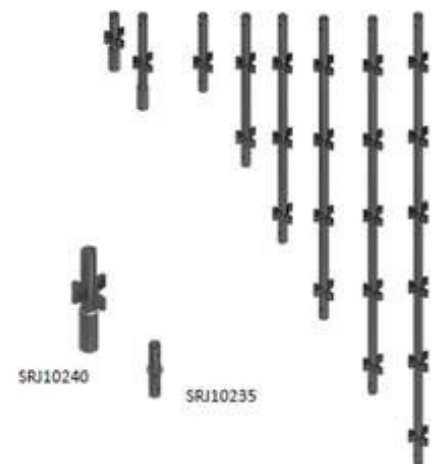

## KWIKSTAGE LEDGER

CODE	REFERENCE NO.	DESCRIPTION
MSKL500	500	2.40
MSKL900	900	3.20
MSKL1200	1500	4.20
MSKL1500	1800	5.00
MSKL1800	2000	6.20
MSKL2000	2500	6.40
MSKL2500		7.40



## KWIKSTAGE STEELBOARD SERIES

CODE	LENGTH (MM)	WEIGHT KG
MSKSB2500	2500	17.80
MSKSB2000	2000	15.40
MSKSB1500	1294	10.60
MSKSB1294	900	9.50
MSKSB900		5.50



## KWIKSTAGE TOEBOARD SERIES

CODE	LENGTH (MM)	WEIGHT KG
MSKSTB1500	1500	8.20
MSKSTB2000	2000	11.60
MSKSTB2500	1294	14.30
MSKSTB1294		7.51

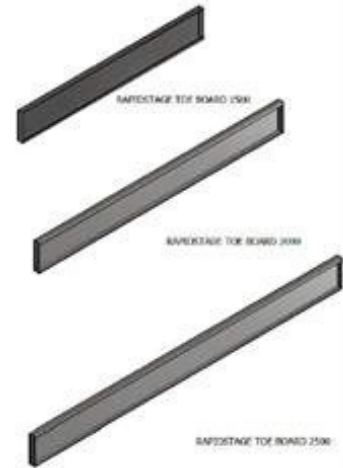

## KWIKSTAGE TOEBOARD CLIP

CODE	LENGTH (MM)	WEIGHT KG
MSKTBC	150	2.00

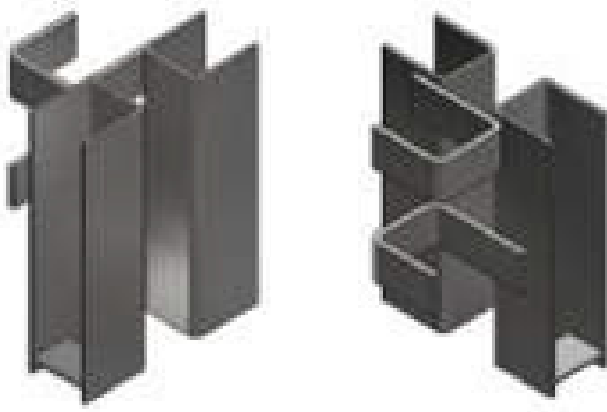

## KWIKSTAGE STAIRCASE

CODE	LENGTH (MM)	WEIGHT KG
MSKSC2X3	2900	85.00



# PA H-FRAME WITH BRACING

Light Duty H-frame scaffolds are provided with special lattices to enable safe & easy access for workers and are best suited for access scaffolding applications. The frames are interconnected by scissor-type cross-braces, which are secured to the H-frames by specially designed pins, welded onto the frames, and locked in position.

- Excellent rigidity due to welded construction & cross-bracings.
- No tools are required for erection.
- Quick & easy to erect. Erection can be done even by unskilled labor.
- Excellent for use as scaffold tower around concrete hoist.
- Ideal for use as access scaffolding.

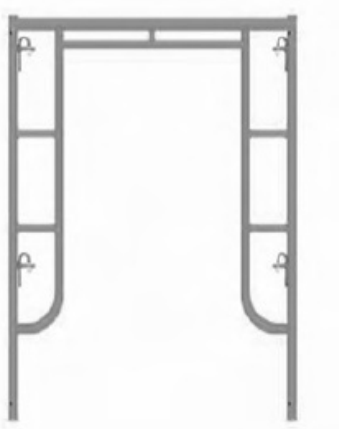
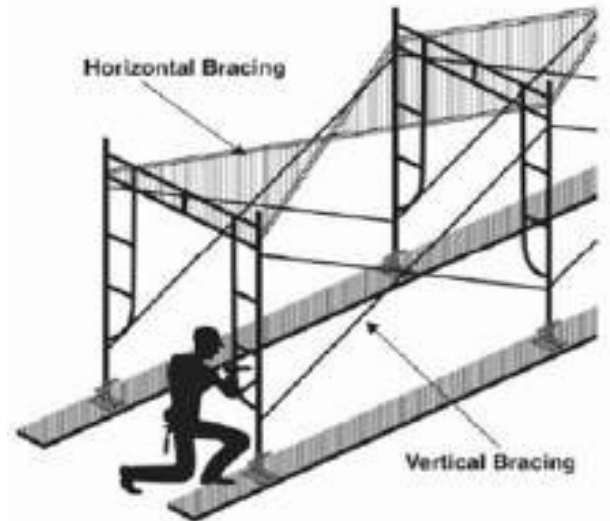

## WALK THROUGH FRAME

CODE	SIZE (MM)	WEIGHT (KG)
EFC -8001	2006*1524	20.00
EFC -8001	1930*1524	19.50
EFC -8001	1219*1700	15.00
EFC -8001	1219*1930	16.50
EFC -8001	914*1700	14.00

## WALK THROUGH FRAME

CODE	SIZE (MM)	WEIGHT (KG)
EFC -8002	128*762	11.00
EFC -8002	1524*762	13.00
EFC -8002	914*762	10.00

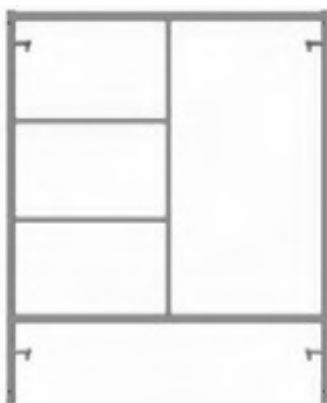

## MASON FRAME

CODE	SIZE (MM)	WEIGHT (KG)
EFC -8001	2006*1524	22.00
EFC -8001	1524*1524	18.00
EFC -8001	1220*1524	16.00
EFC -8001	914*1524	14.00

## EFC - 8008



## CROSS BRACE

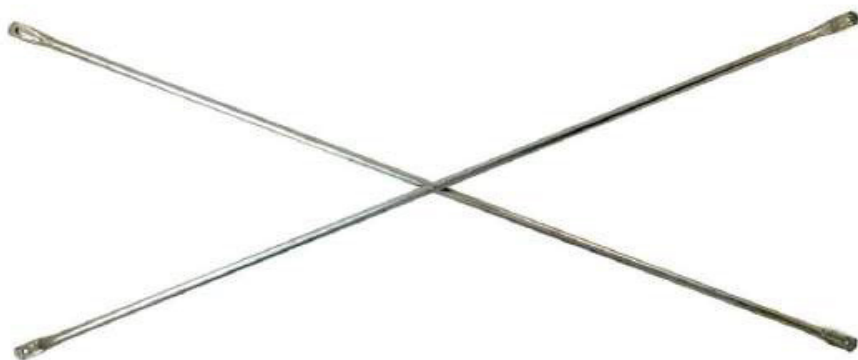

CODE	SIZE (MM)	WEIGHT (KG)
EFC -8009	1219*610	4.50
EFC -8009	1219*914	5.50
EFC -8009	1219*1219	7.00
EFC -8009	1524*610	7.50
EFC -8009	1829*610	8.00
EFC -8009	1829*914	8.40

# PA H-FRAME & BRACING

## H-FRAME WITH LADDER

CODE	SIZE (MM)	WEIGHT (KG)
PA - 1156 - 1	2000*1000	23.50
PA - 1156 - 2	2500*1000	26.75



## H-FRAME

CODE	SIZE (MM)	WEIGHT (KG)
PA - 1156 - 3	2000*1000	20.00
PA - 1156 - 4	2500*1000	23.00

## BRACING WITH PIPE

CODE	SIZE (MM)	WEIGHT (KG)
PA - 1157 - 1	2000	6.50
PA - 1157 - 3	2500	7.50

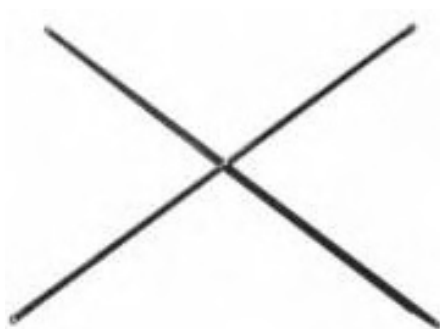

## BRACING WITH ANGLE

CODE	SIZE (MM)	WEIGHT (KG)
PA - 1157 - 2	2000	7.50

# PA DECKING SYSTEM

## DECKING BEAM

CODE	SIZE (MM)	WEIGHT (KG)
PA - 1710 - 01	0.9	5.00
PA - 1710 - 02	1.2	6.50
PA - 1710 - 03	1.5	8.10

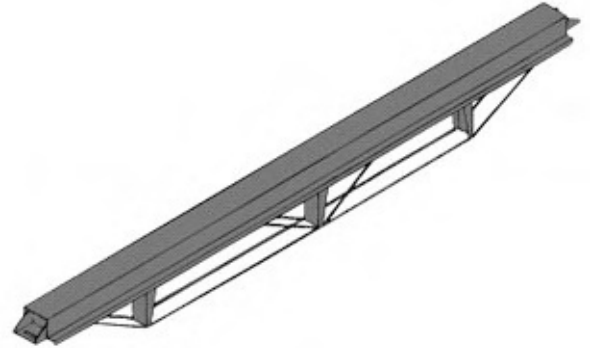

Including a 100mm wide top flange eliminates the necessity for plywood infill, so cutting down maintenance costs.

## INFILL BEAM



CODE	SIZE (MM)	WEIGHT (KG)
PA - 1710 - 01	1.2	11.90
PA - 1710 - 02	1.8	18.00
PA - 1710 - 03	2.5	8.10

Used in providing skeletal support for plywood decking.

## DROP HEAD

CODE	SIZE (M)	WEIGHT (KG)
PA - 1713 - 01	40 KN	6.50

The quick action drop head supplied along with nuts & bolts is designed to fit on standard props or adaptors for cup lock scaffolding.

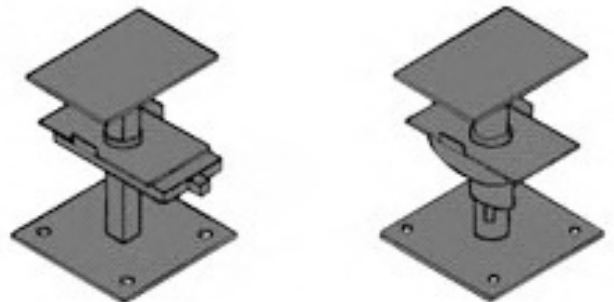

# PA WALKWAY BOARD

## GI WALK BOARD (HOOK TYPE)

CODE	SIZE (MM)	WEIGHT (KG)
PA - 1167 - 01	1500	10.20
PA - 1167 - 02	2000	13.40
PA - 1167 - 03	2500	16.50



## M. S. SHEET PLANK

CODE	SIZE (MM)	WEIGHT (KG)
PA - 1167 - 04	1500	10.00
PA - 1167 - 05	2000	11.80
PA - 1167 - 06	2500	16.00



## WALKWAY BOARD (MAKE SQUARE PIPE)

CODE	SIZE (MM)	WEIGHT (KG)
PA - 1167 - 07	1500	16.50
PA - 1167 - 08	2000	18.20



## WALKWAY BOARD WITH HOOK

CODE	SIZE (MM)	WEIGHT (KG)
PA - 1167 - 07	1500	16.50
PA - 1167 - 08	2000	18.20



# PA ADJUSTABLE PROPS & SBSIPL ADJUSTABLE JACKY

Adjustable Props are economical and popular instruments used to support concrete elements. It's economical to hire or buy an easier and quick erection, safe load support. The most important part of the props is the threaded portion called the collar.

They provide the best temporary support for all-purpose.

We are a leading manufacturer of scaffolding props and also an exporter of adjustable props, recommended by construction industries around the world

Props are manufactured in four categories:

- Light Duty Prop
- Medium Duty Prop
- Heavy Duty Prop
- Push-Pull Prop

All props can be manufactured in any size on demand, and the rocking top to the bottom plate is also available in any size.



**G PIN**



**PROP SLEEVE**



**PROP NUT**



## ADJUSTABLE PROPS (LIGHT DUTY)

CODE	SIZE (MM)	WEIGHT (KG)
SB - 1154 - 05	1500*1500	12.70
SB - 1154 - 06	2000*2000	16.40
SB - 1154 - 07	2000*2500	17.50
SB - 1154 - 08	2000*3000	19.20



### ADJUSTABLE PROPS (MEDIUM DUTY)



CODE	SIZE (MM)	WEIGHT (KG)
SB - 1154 - 01	1500*1500	14.50
SB - 1154 - 02	2000*2000	18.00
SB - 1154 - 03	2000*2500	20.00
SB - 1154 - 04	2000*3000	22.00
SB - 1154 - 05	3000*3000	26.00

### ADJUSTABLE PROPS (HEAVY DUTY)

CODE	SIZE (MM)	WEIGHT (KG)
SB - 1156 - 01	1500*1500	16.50
SB - 1156 - 02	2000*2000	20.00
SB - 1156 - 03	2000*2500	22.00
SB - 1156 - 04	2000*3000	24.00
SB - 1156 - 05	3000*3000	28.00

### ADJUSTABLE PROPS (EX. HEAVY DUTY)

CODE	SIZE (MM)	WEIGHT (KG)
SB - 1157 - 05	1500*1500	18.70
SB - 1157 - 06	2000*2000	22.40
SB - 1157 - 07	2000*2500	26.50
SB - 1157 - 08	2000*3000	30.20

### PUSH - PULL PROP



CODE	SIZE (MM)	WEIGHT (KG)
SB - 1164	1.5*2.5	12.50

### PUSH - PULL PROP



CODE	SIZE (MM)	WEIGHT (KG)
GIPR1.5x 2.0S	1500X1500	14.00
GIPR1.7x 2.0S	1700X2000	11.50
GIPR1.7x 2.0S	2000X2000	17.50

# PA BASE PLATE

## BASE PLATE



CODE	TUBE OD (MM)	WEIGHT (KG) PAINTED
SB - 1166 - 01	38	1.30

## BASE PLATE WITH HOLE



CODE	TUBE OD (MM)	WEIGHT (KG) PAINTED
SB - 1166 - 02	38	1.30

## PA TRIPOD



CODE	TUBE OD (MM)	WEIGHT (KG) PAINTED
SB - 1155 - 01	38	10.90



CODE	TUBE OD (MM)	WEIGHT (KG) PAINTED
SB - 1155 - 02	38	10.90

# PA ADJUSTABLE SPAN

## ACROW SPAN

CODE	SIZE (MM)	WEIGHT (KG)
SB - 1158 - 01	2000*2000	35.00
SB - 1158 - 01	2000*2500	38.00
SB - 1158 - 01	2300*2300	40.00
SB - 1158 - 01	2500*2500	44.00

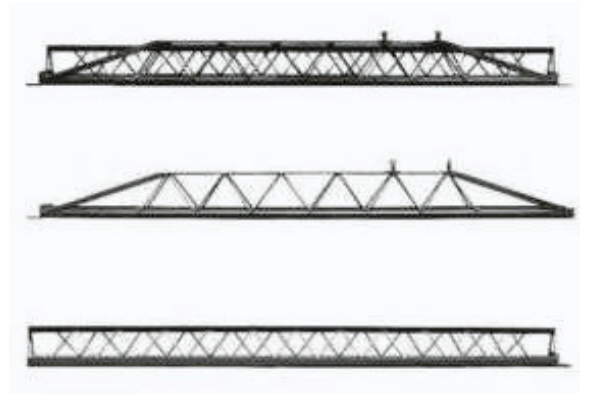

## BOX SPAN

CODE	TUBE OD (MM)	WEIGHT (KG) PAINTED
SB - 1159 - 01	2000*2000	26.00
SB - 1159 - 02	3000*3000	39.00



## I BEAM SPAN

CODE	TUBE OD (MM)	WEIGHT (KG) PAINTED
SB - 1163 - 01	100*50*8000	48.00
SB - 1163 - 02	125*70*8000	80.00

# PA SHUTTERING PLATES



## SHUTTERING PLATE

CODE	SIZE (MM)	WEIGHT (KG)
SB - 1165 - 01	600*900	15.50

## SHUTTERING PLATE

CODE	SIZE (MM)	WEIGHT (KG)
SB - 1165 - 02	450*900	12.50

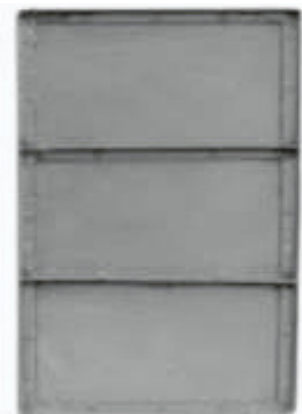

## SHUTTERING PLATE

CODE	SIZE (MM)	WEIGHT (KG)
SB - 1165 - 03	1250*500	26.00



## WALLFORM PLATE

CODE	SIZE (MM)	WEIGHT (KG)
SB - 1165 - 03	1250*500	26.00

# PA JACK

## ADJUSTABLE BASE JACK

CODE	TUBE (MM)	TL\AL (M)	WEIGHT (KG)
SB - 1144	38 X 4	0.450 / 0.300	3.45
SB - 1145	38 X 4	0.550 / 0.400	3.38
SB - 1146	38 X 4	0.650 / 0.500	3.71
SB - 1147	38 X 4	0.750 / 0.600	4.05



## ADJUSTABLE BASE JACK

CODE	TUBE (MM)	TL\AL (M)	WEIGHT (KG)
SB - 1148	38 X 4	0.450 / 0.300	5.38
SB - 1149	38 X 4	0.550 / 0.400	5.71
SB - 1150	38 X 4	0.650 / 0.500	6.05
SB - 1151	38 X 4	0.750 / 0.600	6.38

## ADJUSTABLE BASE JACK

CODE	TUBE (MM)	TL\AL (M)	WEIGHT (KG)
SB - 1144	38 X 4	0.450 / 0.300	1.99
SB - 1145	38 X 4	0.550 / 0.400	2.33
SB - 1146	38 X 4	0.650 / 0.500	2.66
SB - 1147	38 X 4	0.750 / 0.600	3.00



# PA FITTINGS - FORGED

## SWIVEL COUPLER

CODE	TUBE OD (MM)	WEIGHT ZINC
EN - 74 - 1	48*48	1.05



## FIXED COUPLER

CODE	TUBE OD (MM)	WEIGHT ZINC
EN - 74	48*48	0.95



## SWIVEL COUPLER

CODE	TUBE OD (MM)	WEIGHT ZINC
EN - 74 - 1	48*60	1.02



## FIXED COUPLER

CODE	TUBE OD (MM)	WEIGHT ZINC
EN - 74	48*60	1.10

## SWIVEL COUPLER

CODE	TUBE OD (MM)	WEIGHT ZINC
EN - 74 - 1	60*60	1.50



## FIXED COUPLER

CODE	TUBE OD (MM)	WEIGHT ZINC
EN - 74	48*60	1.23

# PA FITTINGS - FORGED

## BOARD RETAINING CLAMP (BRC)

CODE	TUBE OD (MM)	WEIGHT ZINC
BS - 1139	48	0.55



## TOE BOARD COUPLER

CODE	TUBE OD (MM)	WEIGHT ZINC
BS - 1139 - 48	48	0.65

## DOUBLE / GIRDER BEAM / GRAVELOCK COUPLER

CODE	TUBE OD (MM)	WEIGHT ZINC
BS - 1139 - 48	48	1.30

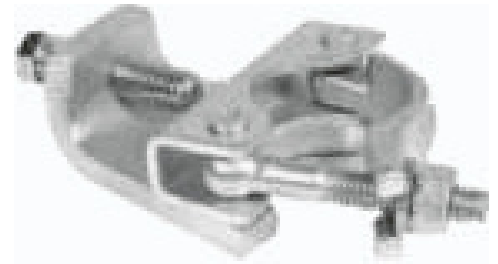

## WING NUT

CODE	TUBE OD (MM)	WEIGHT ZINC
EN - 74	16	0.22

## ANCHOR NUT

CODE	TUBE OD (MM)	WEIGHT ZINC
BS - 1139	25	0.40



## TIE ROD CONNECTOR

CODE	TUBE OD (MM)	WEIGHT ZINC
EN - 74	16	0.60

# PA FITTINGS - SHEET METAL

## SWIVEL COUPLER

CODE	TUBE OD (MM)	WEIGHT (KG)
BS - 1139	48*48	0.75



## FIXED COUPLER

CODE	TUBE OD (MM)	WEIGHT (KG)
BS - 1139 - 48	48	0.65



## SWIVEL COUPLER

CODE	TUBE OD (MM)	WEIGHT (KG)
BS - 1139 - 48	48*60	0.80



## FIXED COUPLER

CODE	TUBE OD (MM)	WEIGHT (KG)
EN - 74	48*60	0.70



## SWIVEL COUPLER

CODE	TUBE OD (MM)	WEIGHT (KG)
BS - 1139 - 60	60*60	0.85



## FIXED COUPLER

CODE	TUBE OD (MM)	WEIGHT (KG)
BS - 1139 - 60	60*60	0.75

# PA FITTINGS - SHEET METAL

## JOINT PIN

CODE	TUBE OD (MM)	WEIGHT (KG)
BS - 1140	48	0.65



## SLEEVE COUPLER

CODE	TUBE OD (MM)	WEIGHT (KG)
BS - 1141	48	1.12

## PUT LOG COUPLER

CODE	TUBE OD (MM)	WEIGHT (KG)
BS - 1142	48	0.64



## SINGLE WEDGE COUPLER

CODE	TUBE OD (MM)	WEIGHT (KG)
BS - 1142	48	0.70

## LADDER CLAMP

CODE	TUBE OD (MM)	WEIGHT (KG)
BS - 1142	48	0.64



## GRAVLOCK COUPLER

CODE	TUBE OD (MM)	WEIGHT (KG)
BS - 1143	48	1.51

# PA ACCESSORIES

## PROP NUT WITH HANDLE

CODE	DIA (MM)	WEIGHT (KG)
SB - 1166	60	0.75



## WALLER WITH WING NUT

CODE	DIA (MM)	WEIGHT (KG)
SB - 1167	120*120*10	1.04



## WALLER PLATE

CODE	DIA (MM)	WEIGHT (KG)
SB - 1168	120*120*10	1.15



## G - PIN

CODE	DIA (MM)	WEIGHT (KG)
SB - 1169	10 / 12 MM	0.30 / 0.40



## BRACE PIN

CODE	DIA (MM)	WEIGHT (KG)
SB - 1170	16	1.01



## SOLID CUP NUT

CODE	DIA (MM)	WEIGHT (KG)
SB - 1171	38	0.18

# PA ACCESSORIES

## LADDER CLAMP (BOX TYPE)

CODE	DIA (MM)	WEIGHT (KG)
SB - 1172	48	1.5



## TOP CUP

CODE	DIA (MM)	WEIGHT (KG)
SB - 1173	48	0.40



## BOTTOM CUP

CODE	DIA (MM)	WEIGHT (KG)
SB - 1174	48	0.18



## CASTER WHEEL

CODE	DIA (MM)	WEIGHT (KG)
SB - 1175	48	2.50



## COLUMN CLAMPS

CODE	DIA (MM)	WEIGHT (KG)
SB - 1176	2	1.06



## EYE NUT BOLT

CODE	DIA (MM)	WEIGHT (KG)
SB - 1177	25	0.20



# PA STEEL RUNNER

It is the primary Steel runner which will run along the direction of the beam, on the top of stirrups.



# PA GI LINTEL

SB makes GI Lintels provide a combination of strength and lightweight, resulting in efficient load-bearing performance and increased productivity on site. They are characterized by their ease of installation in addition to the time as well as money-saving.



# PA SUSPENDED PLATFORM

SB series temporarily installed suspended access equipment is ideal for building facade construction, decoration, cleaning, and maintenance.

It is widely used in elevator installation, shipbuilding, and repairing, or in maintenance works of big-size tanks, bridges, embankments, and chimneys. It is easy to operate, flexible for moving, reliable in safety. Therefore, the SB series versatile knock-down platforms provide workers with safer, easier, and more efficient platform access.

The suspended platforms conform to the national standard GB19155-2003



# PA ALUMINIUM SCAFFOLDING MOBILE TOWER

Technical Specifications for Supply and Testing of Aluminium Mobile Scaffold Tower with Stairway:

- MOC: Aluminium Alloy AA6063
- Cross Support: 2 mts (or) 4 mts (or) 8 mts length Triangular Stabilizers (depends on the scaffold ht.)
- Push on frame: 2 mts push on the frame with 7 rungs for easy climbing
- Toe board: Aluminium toe board
- Frame Joints: Fully TIG Welded Rungs (No Casting, MS parts & rivets in Frame)
- 200 kg/m<sup>2</sup> loading capacity i.e. depending on platform length from 270 kg to max.810 kg
- Birch Wood Platform imported from Hungary.
- Platform at Every 2mts
- 100% Tool-free erection.
- Castors: 200 mm dia castor with locking arrangement meeting German Specifications
- Castor Wheels are procured from Rexello - India's largest manufacturer for Castor wheels. Specially Designed as per GERMAN STANDARDS
- All SBSIPL mobile scaffold towers are designed to meet the standards EN 1004 for mobile working platform, scaffolding category 3 (with load capacity up to 200 kg/sqm)



## PA ALUMINIUM LADDER AND STAIRCASE

Aluminum Wall support single ladder 514-R

- The C Section Size is 2.5/8" x 1.1/4"
- The dimensions of rungs 1" dia non-slip corrugated pipe
- The distance between two-step 12" center to center
- The Ladder is found sturdy & structure.
- The rubber shoes bottom & top.
- The section hardness - HE 30 GRADE
- Ladder as per IS 733





# PARASNATH ALUMINIUM

***AUTHORISED WHOLESALER & STOCKIST***



Contact No. +91 9836622666 / 8617263130 / +91 9331199929 / 9831640153

Factory Address: "Uttsav Park", Dulagarh, Village & P.O. Chaturbhuj Kathi,  
P.S -Sankrail,Para - Hudati Para, Plot No. 55 Phase - 1, Howrah - 711303  
Redg. Office:"Ajit Mansion" 10/1/1C Kalakar Street, 1st Floor, Kolkata-700007  
Croporate Office: "Ecospace Business Tower 5A", 3rd Floor,Suite No. 8,  
Kolkata-700160  
Shop Address: 42/1 Strand Road, Kolkata-700007

info@parasnathaluminium.com | www.parsnathaluminium.com