

SOLAR POWER SECTION

26206

0.622 kg/m

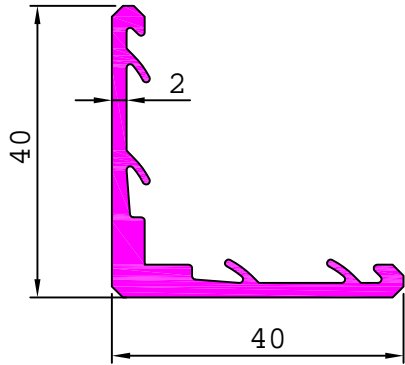

26215

0.365 kg/m

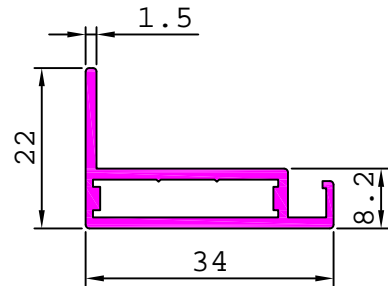

26214

0.261 kg/m

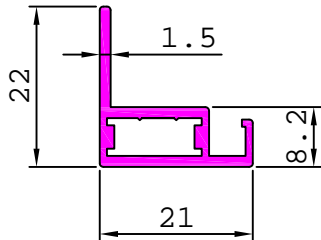

26210

0.578 kg/m

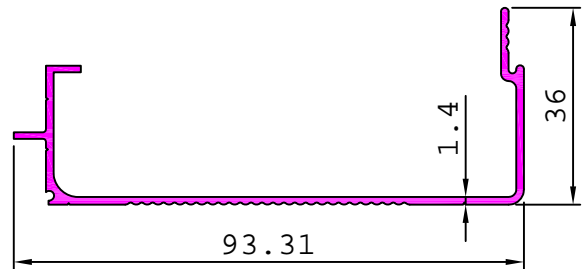

26211

0.688 kg/m

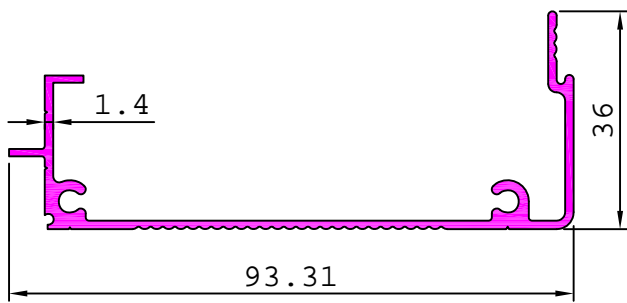

26216

0.941 kg/m

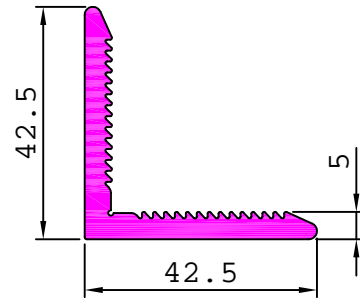

26217

0.552 kg/m

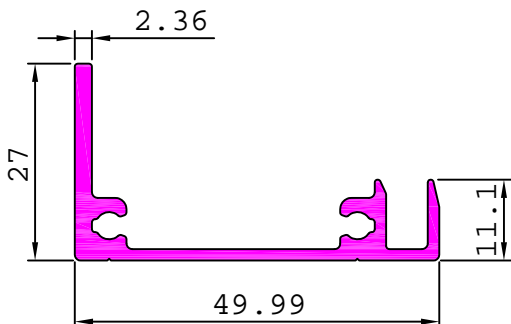

26219

0.285 kg/m

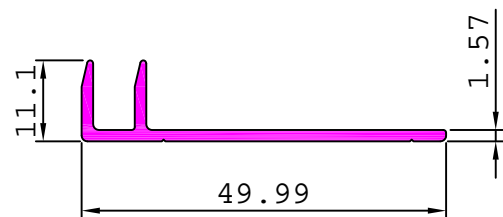

SOLAR POWER SECTION

26225

0.829 kg/m

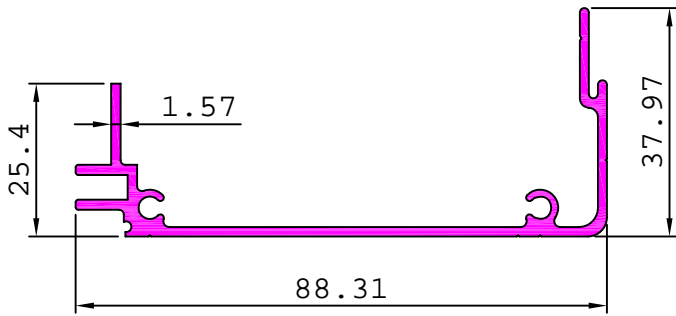

26235

0.494 kg/m

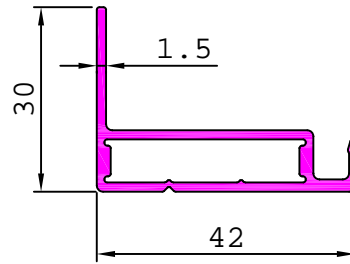

26224

0.141 kg/m

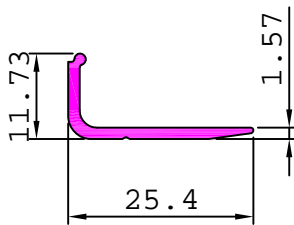

26232

0.111 kg/m

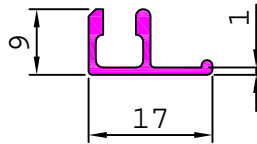

26233

0.163 kg/m

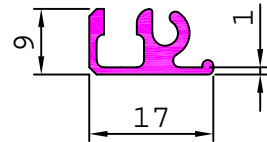

26240

0.339 kg/m

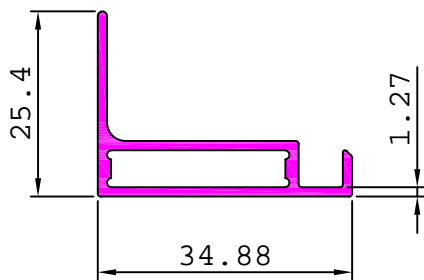

26241

0.633 kg/m

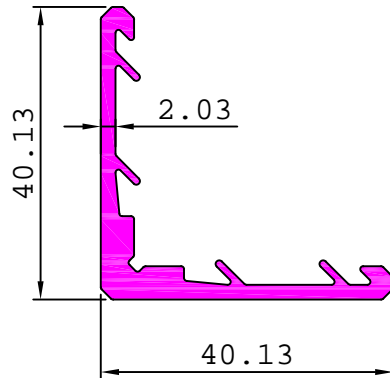

26242

0.605 kg/m

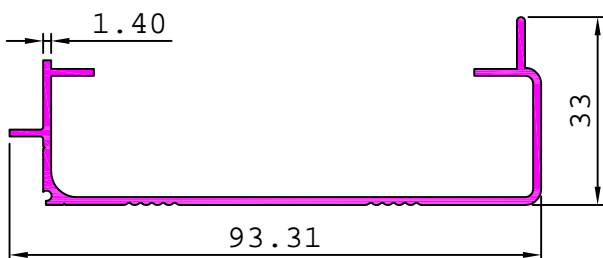

26243

0.716 kg/m

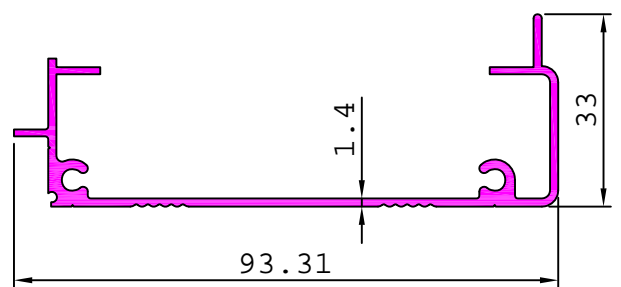

SOLAR POWER SECTION

26245

0.780 kg/m

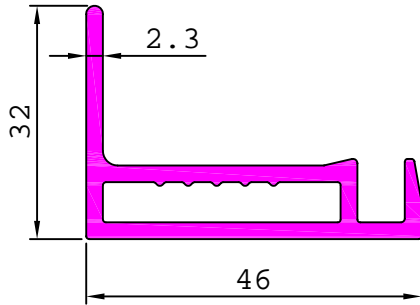

26249

0.531 kg/m

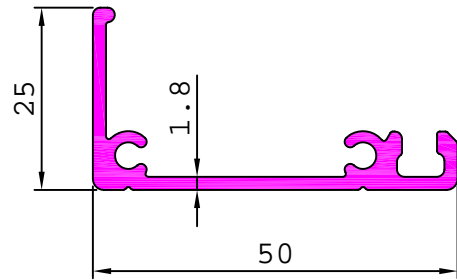

26250

0.315 kg/m

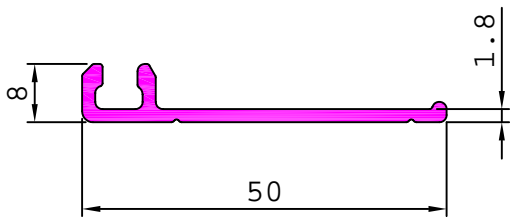

26251

0.483 kg/m

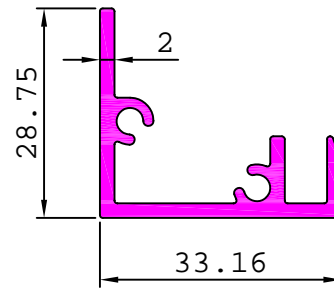

26253

0.627 kg/m

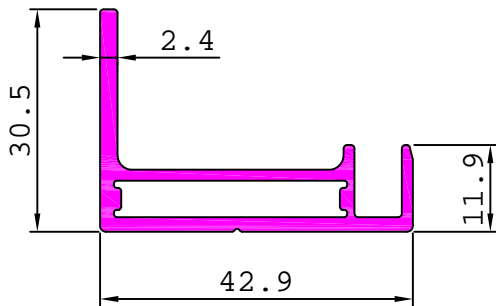

26259

0.374 kg/m

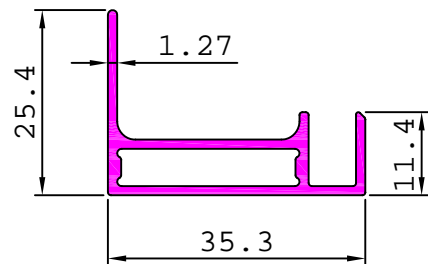

26244

0.198 kg/m

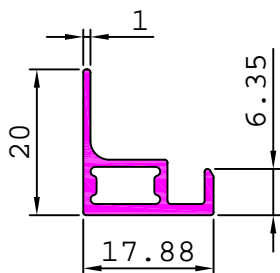

26256

0.256 kg/m

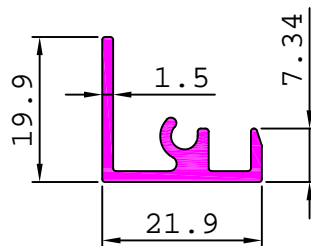

26257

0.133 kg/m

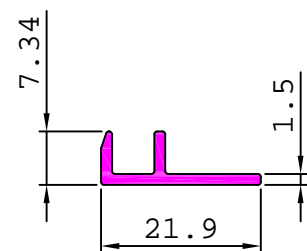

SOLAR POWER SECTION

26258 0.270 kg/m

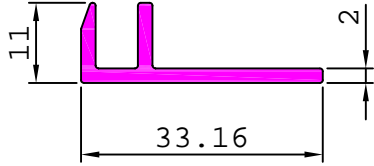

26261 0.113 kg/m

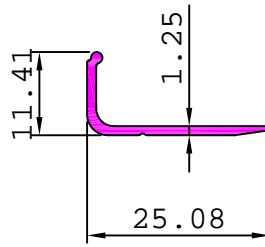

26267 0.173 kg/m

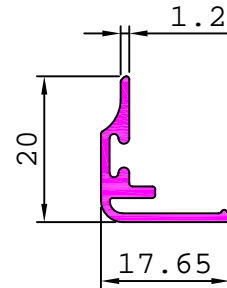

26266 0.372 kg/m

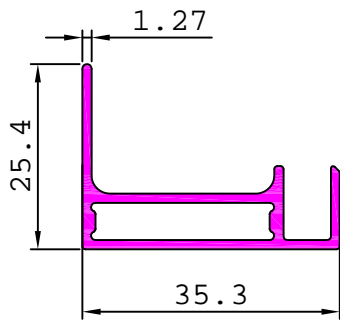

26269 0.631 kg/m

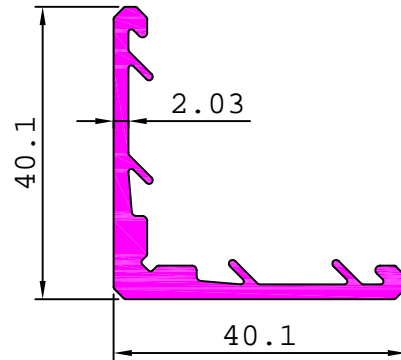

26270 0.378 kg/m

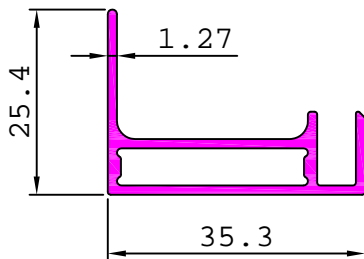

26272 0.344 kg/m

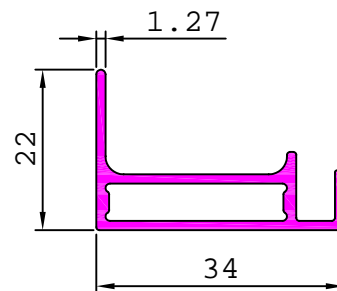

26274 0.618 kg/m

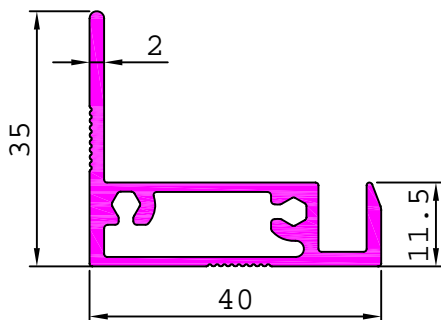

26275 0.525 kg/m

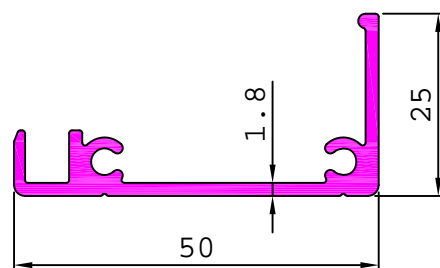

SOLAR POWER SECTION

26276

0.680 kg/m

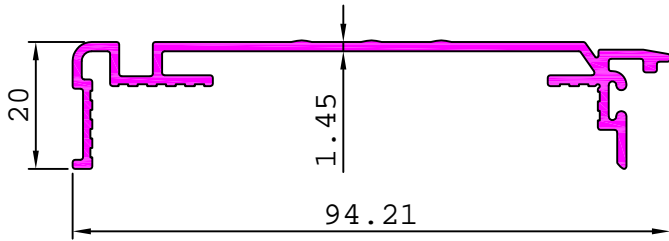

26282

0.571 kg/m

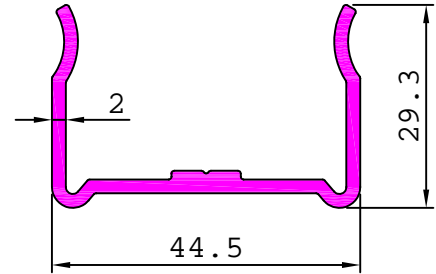

26277

0.308 kg/m

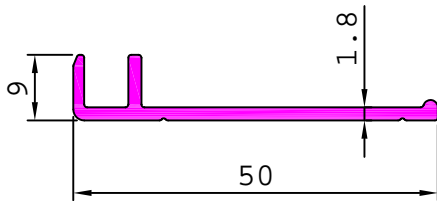

26278

0.355 kg/m

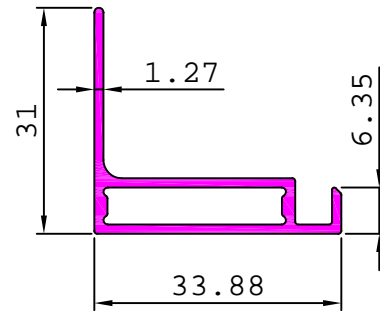

26279

0.721 kg/m

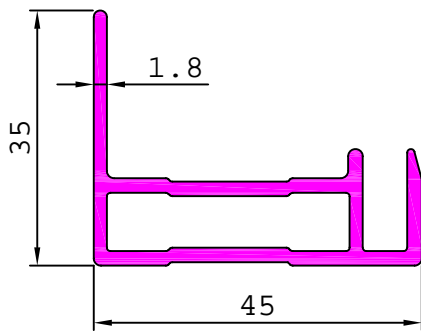

26280

0.967 kg/m

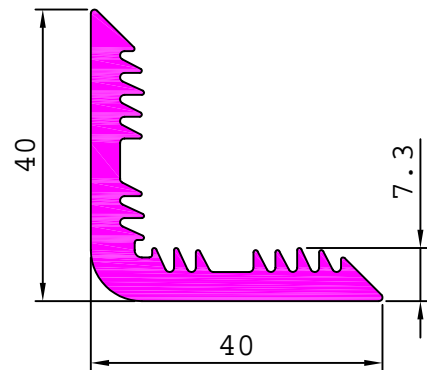

26281

1.055 kg/m

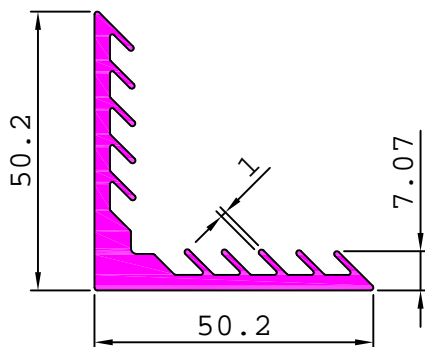

26284

0.614 kg/m

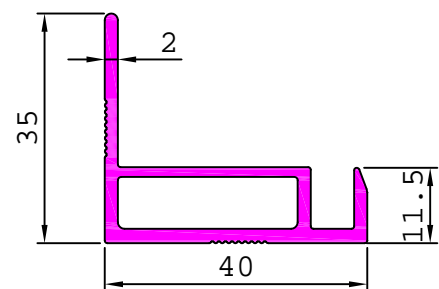

SOLAR POWER SECTION

26283 0.862 kg/m

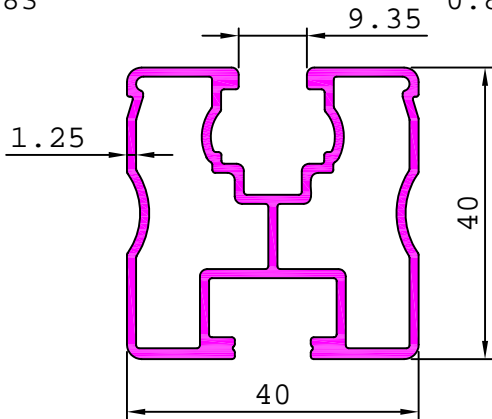

38011 1.176 kg/m

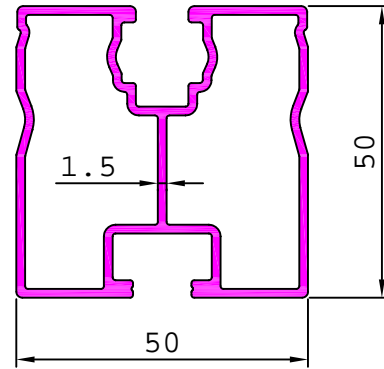

26285 0.648 kg/m

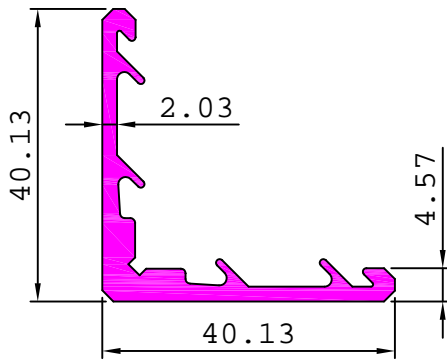

26286 0.741 kg/m

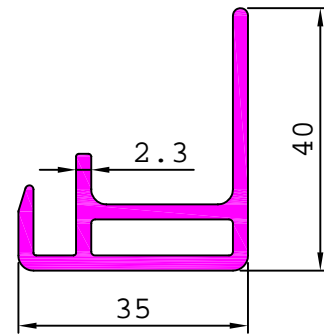

26287 0.273 kg/m

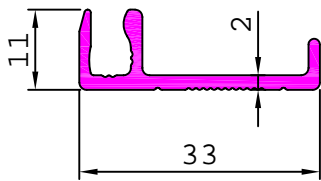

26288 0.419 kg/m

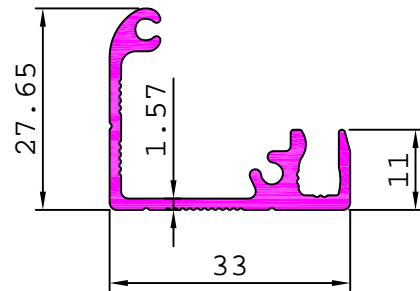

26289 0.595 kg/m

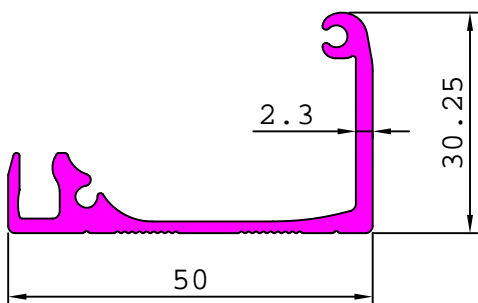

26290 0.599 kg/m

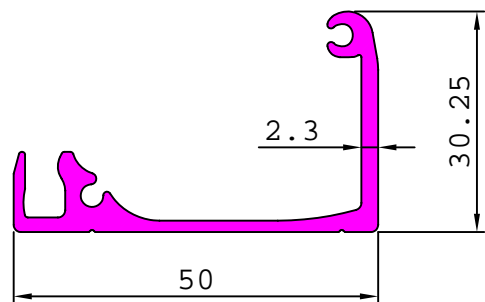

SOLAR POWER SECTION

26291

0.454 kg/m

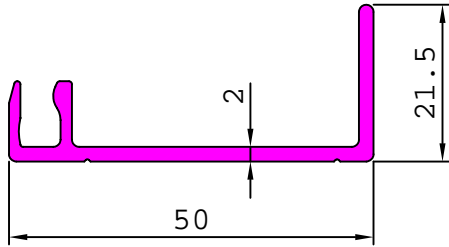

26299

0.343 kg/m

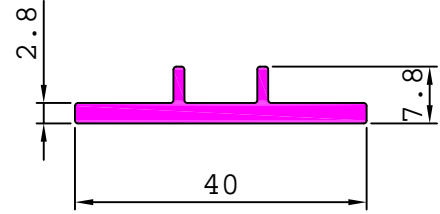

26294

0.380 kg/m

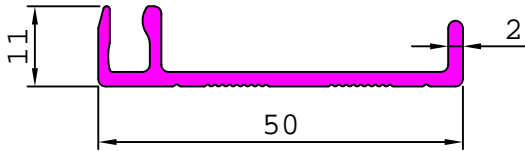

26295

0.419 kg/m

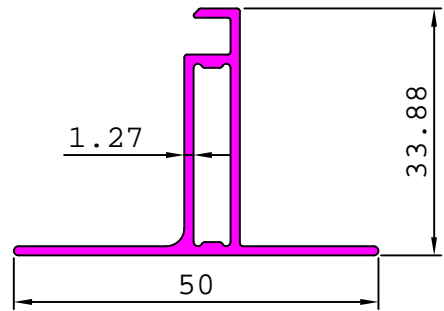

26292

1.028 kg/m

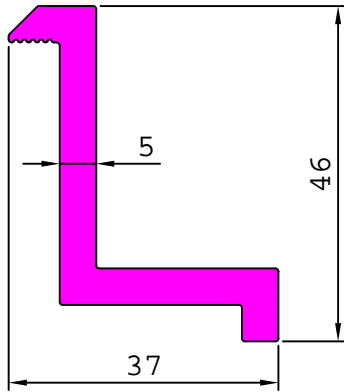

26293

0.933 kg/m

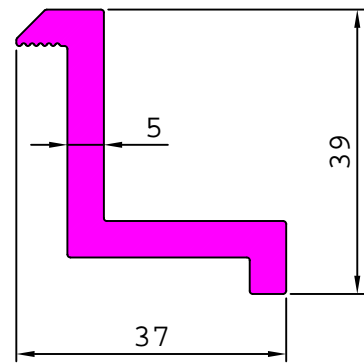

27909

1.365 kg/m

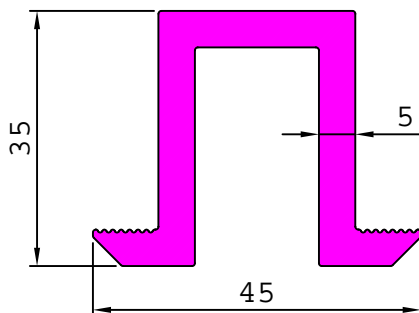

26296

0.404 kg/m

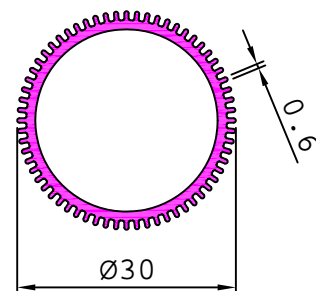

SOLAR POWER SECTION

26297

0.642 kg/m

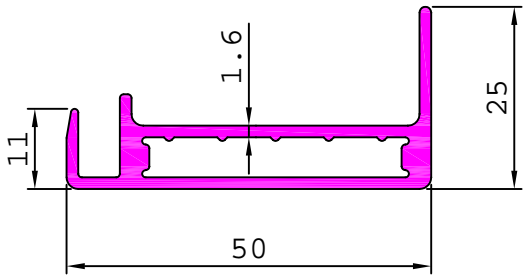

26298

0.520 kg/m

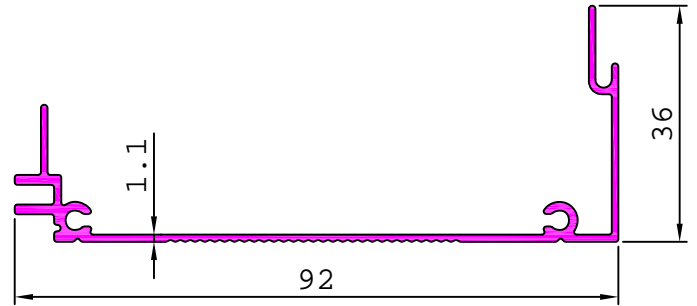

26300

0.475 kg/m

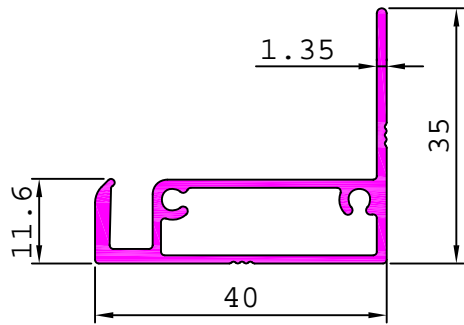

38001

0.392 kg/m

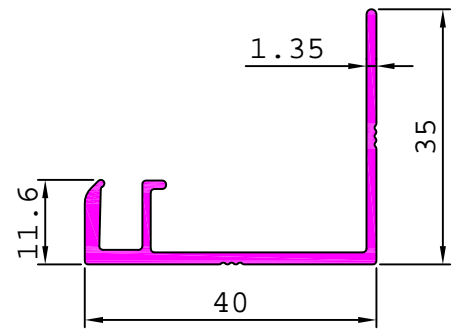

38002

0.837 kg/m

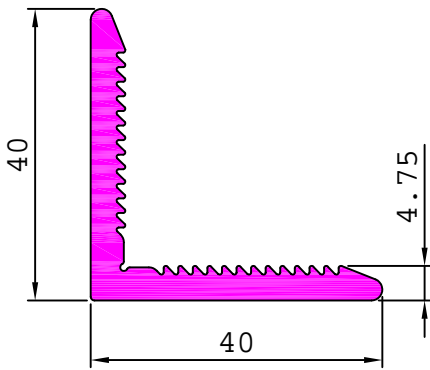

38003

0.636 kg/m

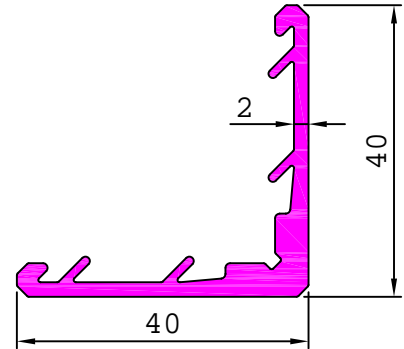

38004

0.546 kg/m

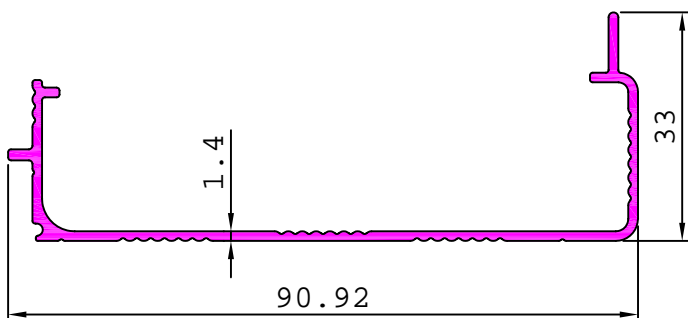

38005

0.650 kg/m

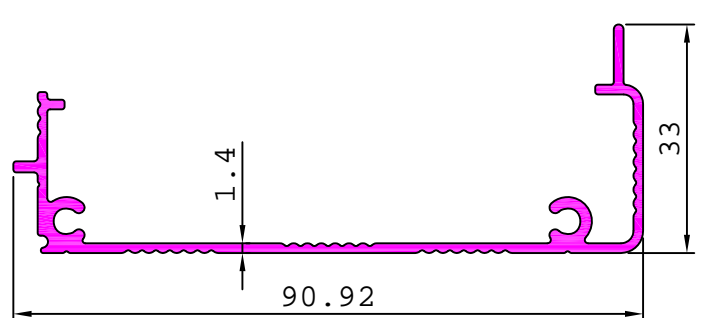

SOLAR POWER SECTION

38006

0.473 kg/m

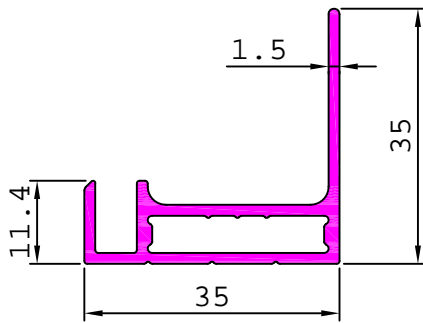

38007

1.201 kg/m

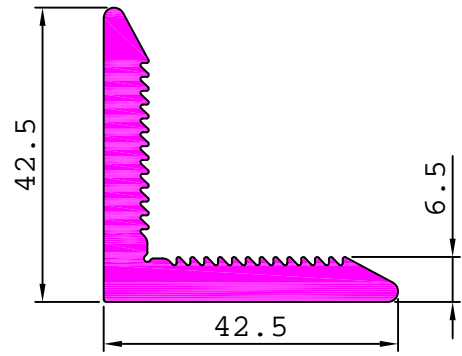

38010

0.660 kg/m

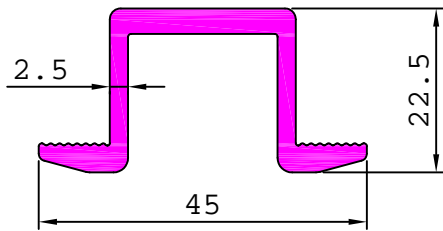

38008

0.954 kg/m

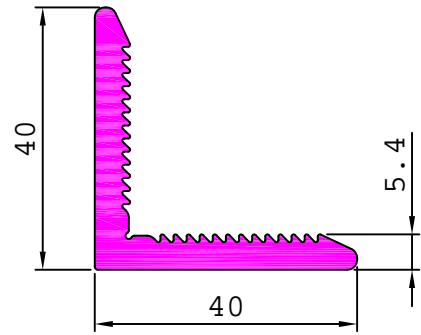

38009

0.493 kg/m

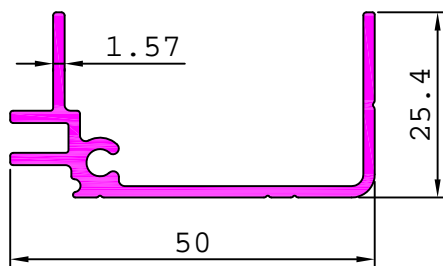

38012

0.402 kg/m

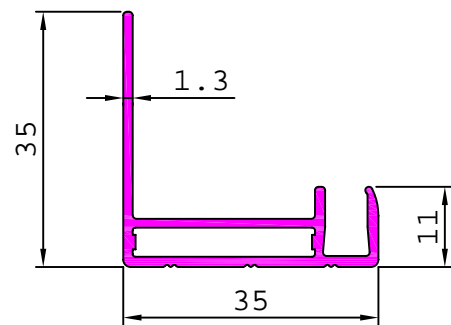

38013

0.374 kg/m

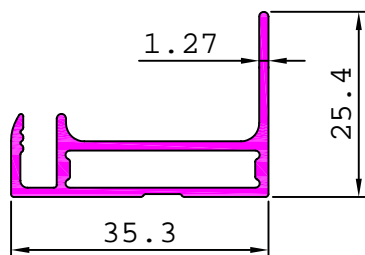

38014

0.339 kg/m

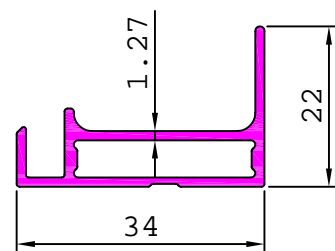

SOLAR POWER SECTION

38015

0.359 kg/m

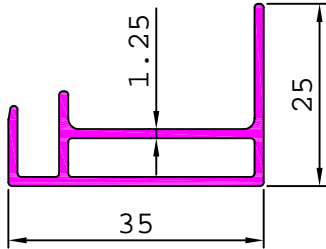

S4507

0.274 kg/m

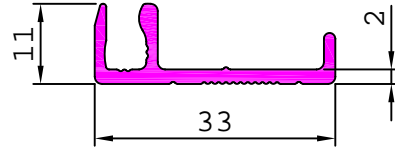

S4508

0.418 kg/m

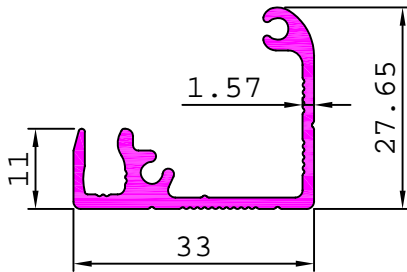

S4509

0.277 kg/m

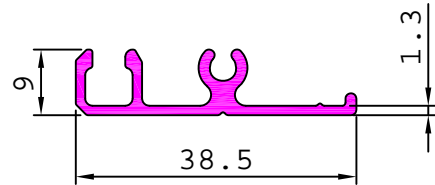

S4510

0.254 kg/m

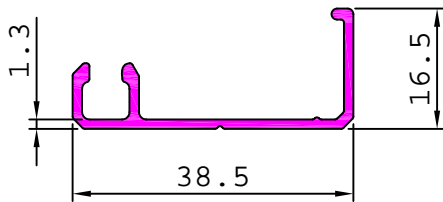

S4335

0.474 kg/m

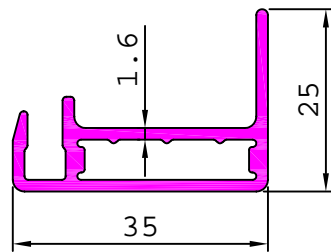

S4483

0.380 kg/m

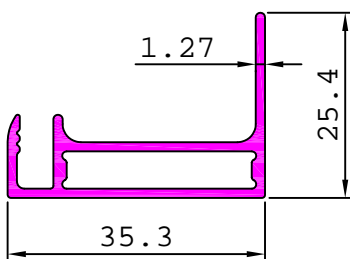

S4923

0.466 kg/m

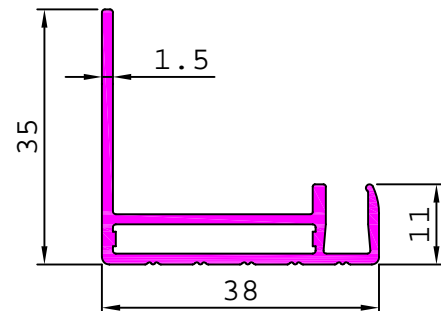



SOLAR POWER SECTION

S4924

0.725 kg/m

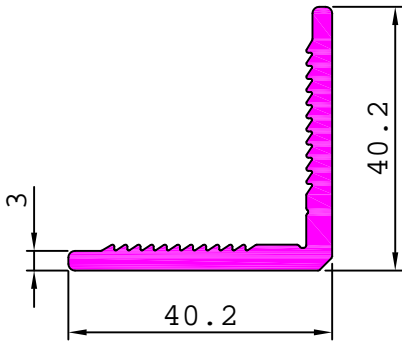

S5899

0.282 kg/m

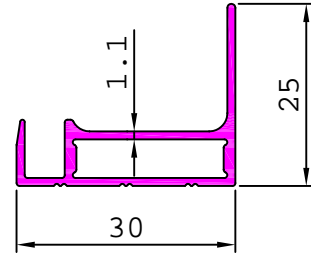

S5972

0.251 kg/m

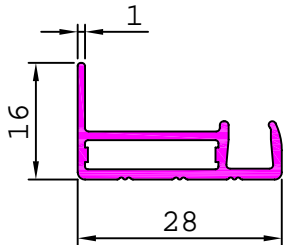

S5984

2.633 kg/m

