

LOUVRE SECTION

20552 0.599 kg/m

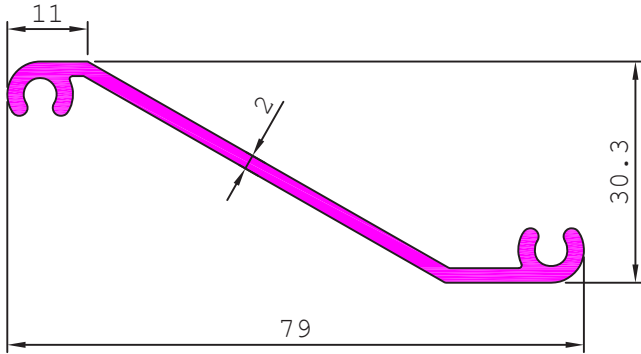

20778 0.483 kg/m

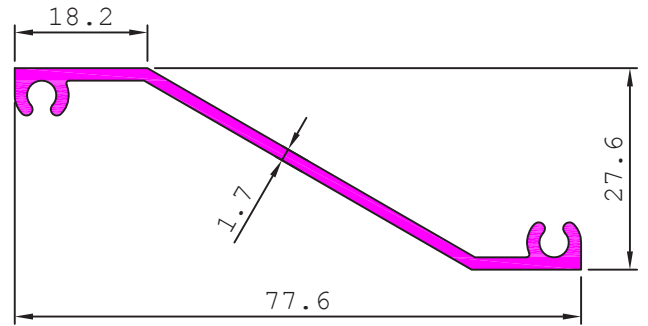

20782 0.429 kg/m

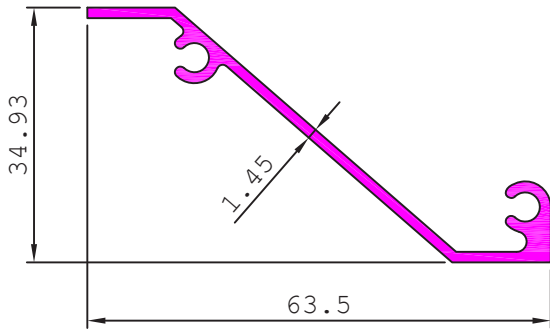

20853 0.391 kg/m

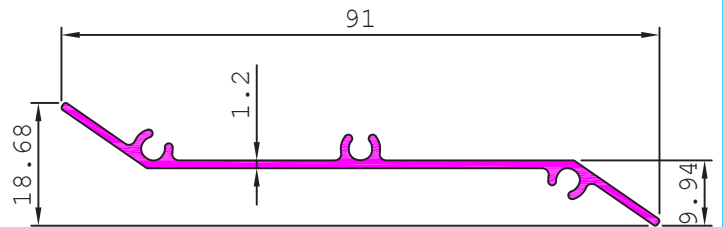

20860 0.249 kg/m

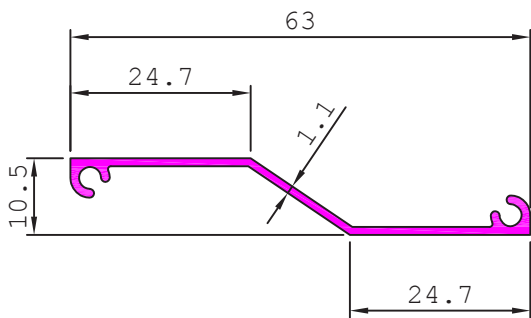

20967 0.369 kg/m

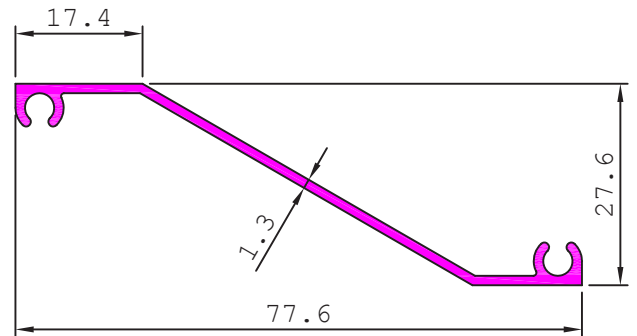

20970 0.248 kg/m

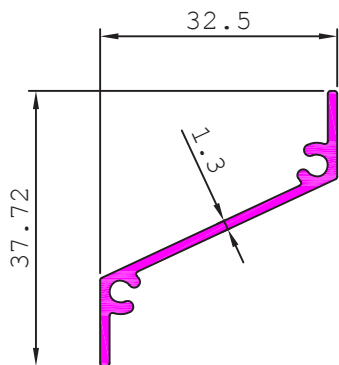

21150 0.519 kg/m

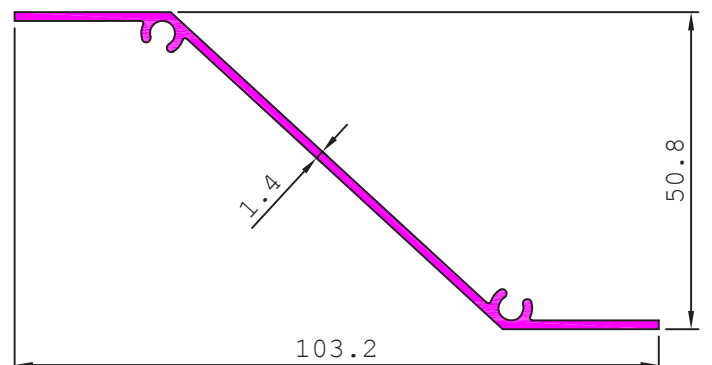

LOUVRE SECTION

21305

0.402 kg/m

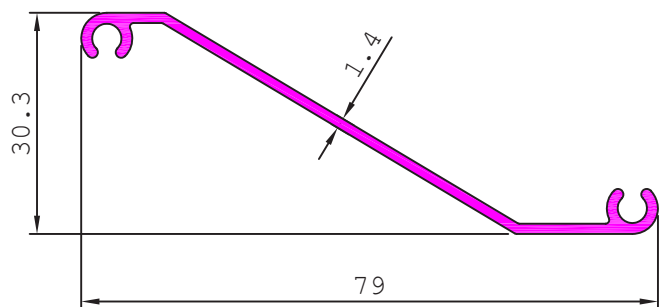

21318

0.514 kg/m

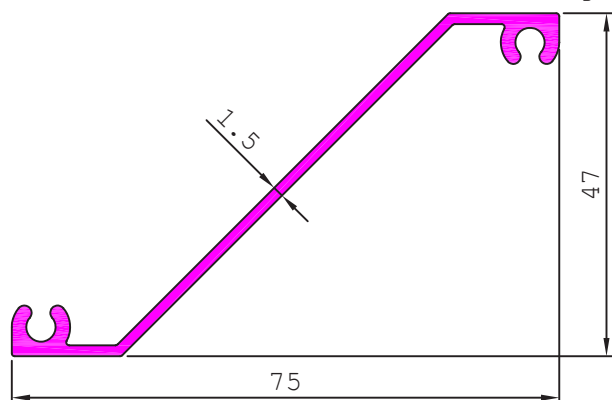

21334

0.543 kg/m

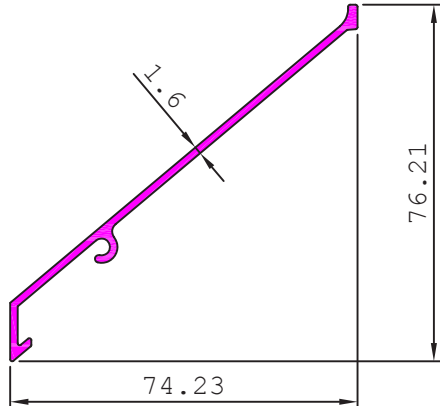

21347

0.420 kg/m

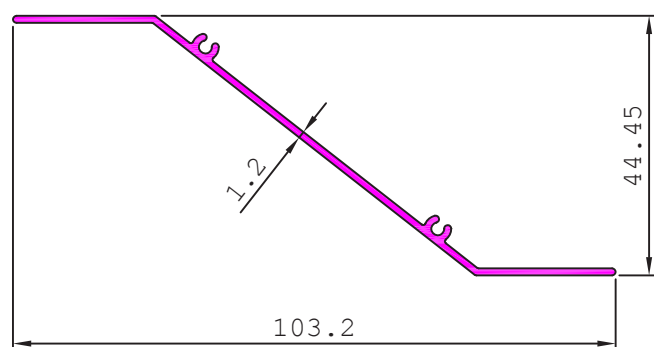

21351

0.288 kg/m

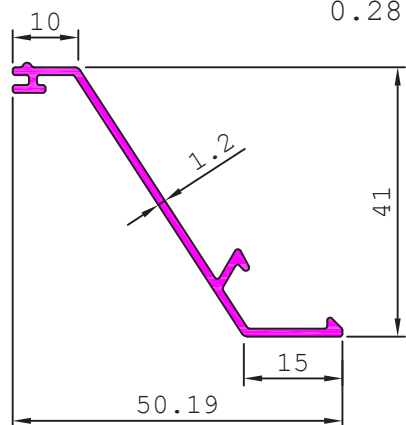

21451

0.249 kg/m

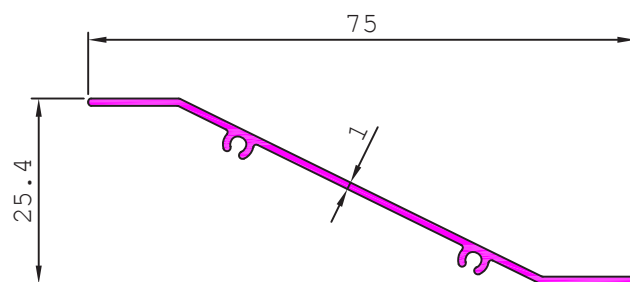

21472

1.111 kg/m

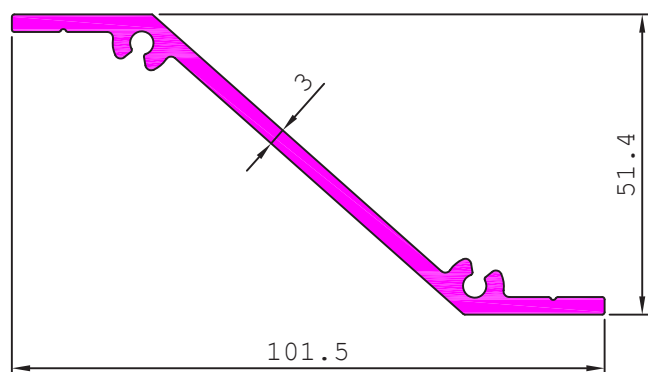

21713

0.385 kg/m

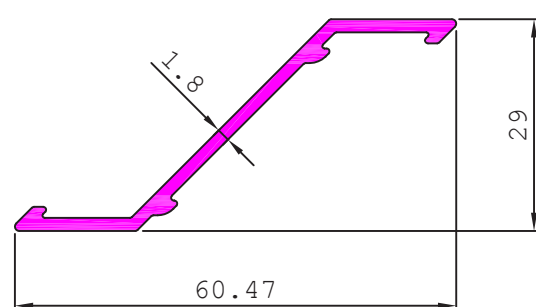

LOUVRE SECTION

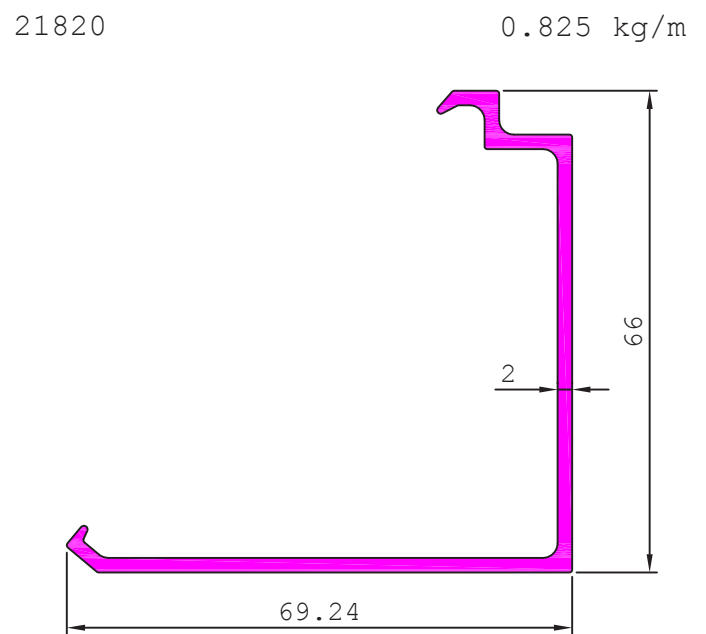
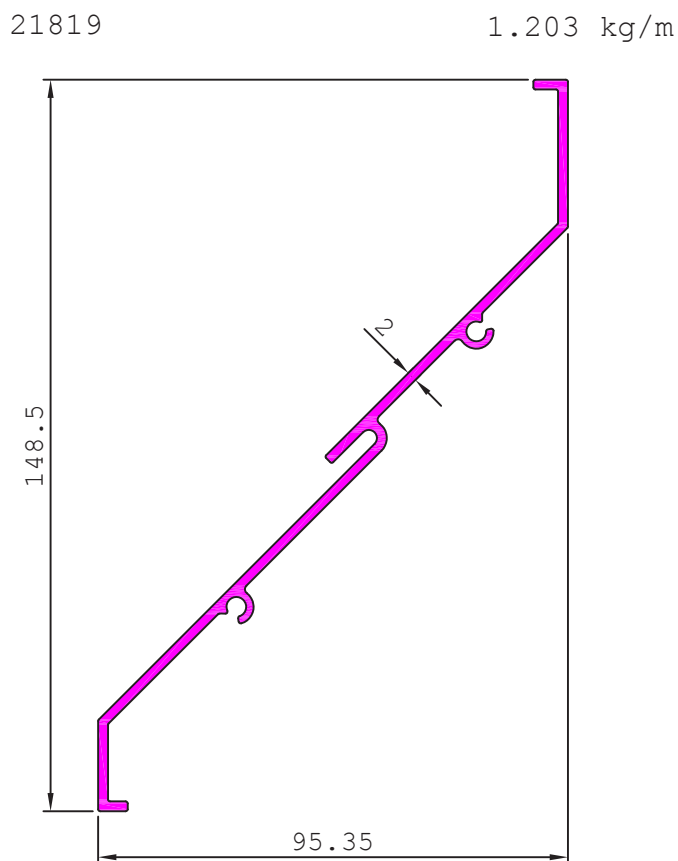
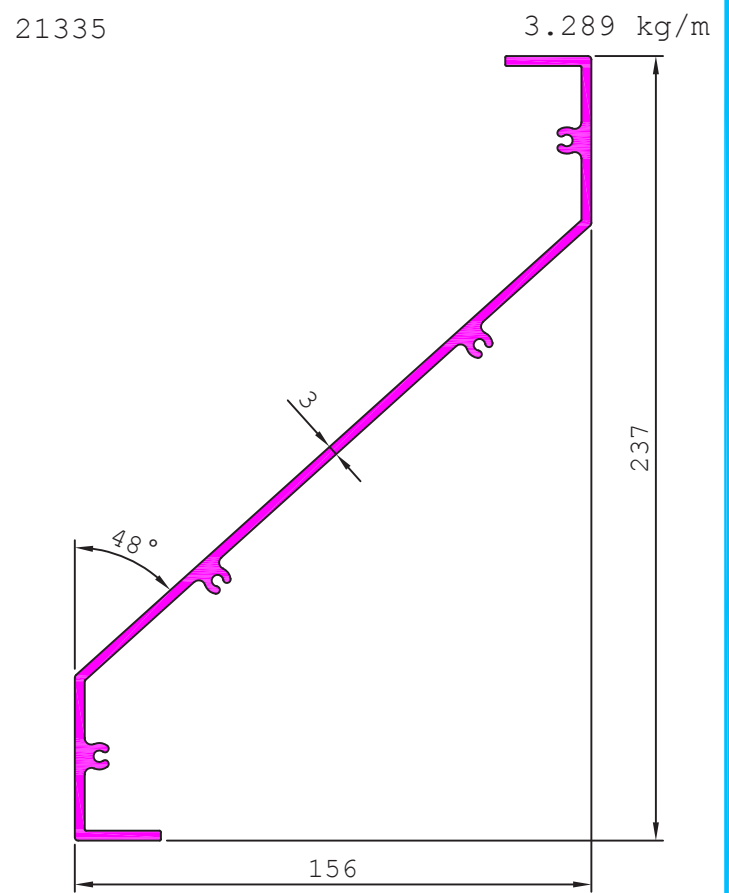
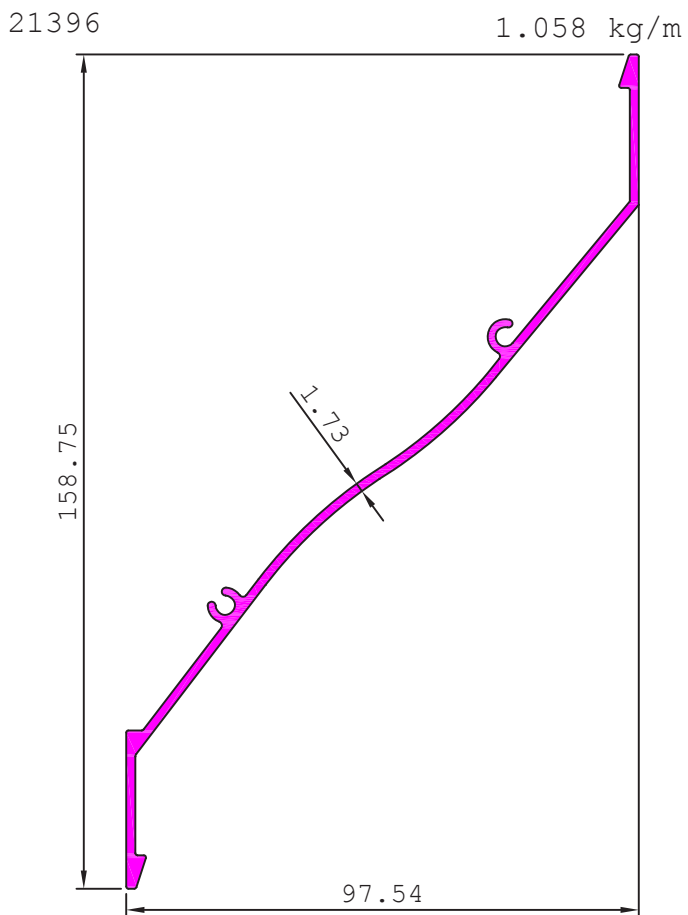

LOUVRE SECTION

21591

0.610 kg/m

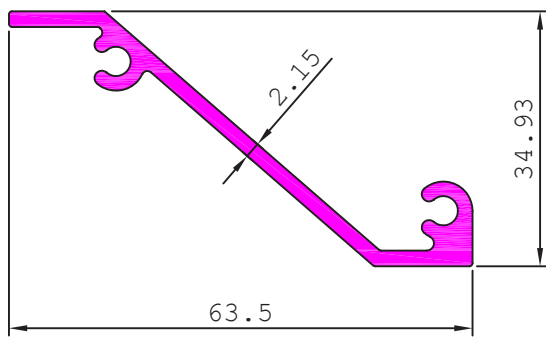

21417

2.014 kg/m

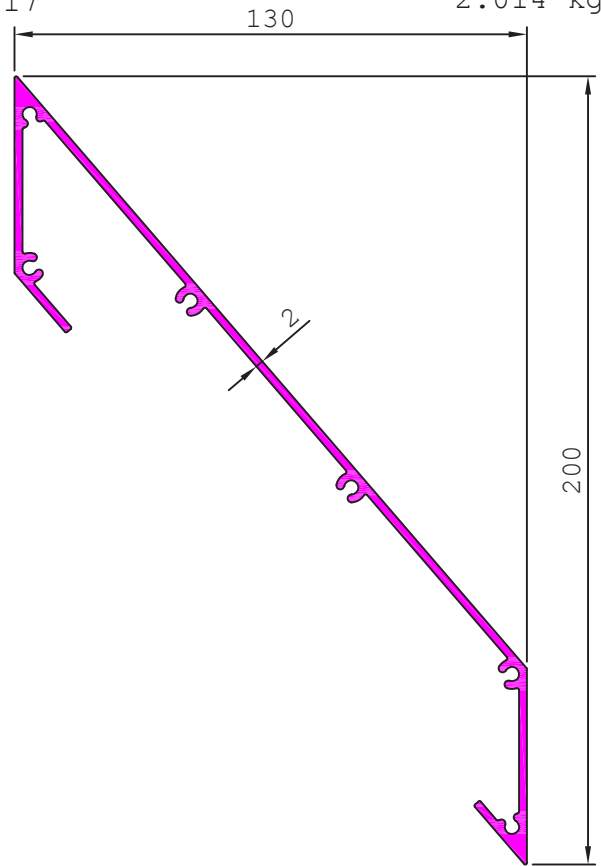

22897

2.216 kg/m

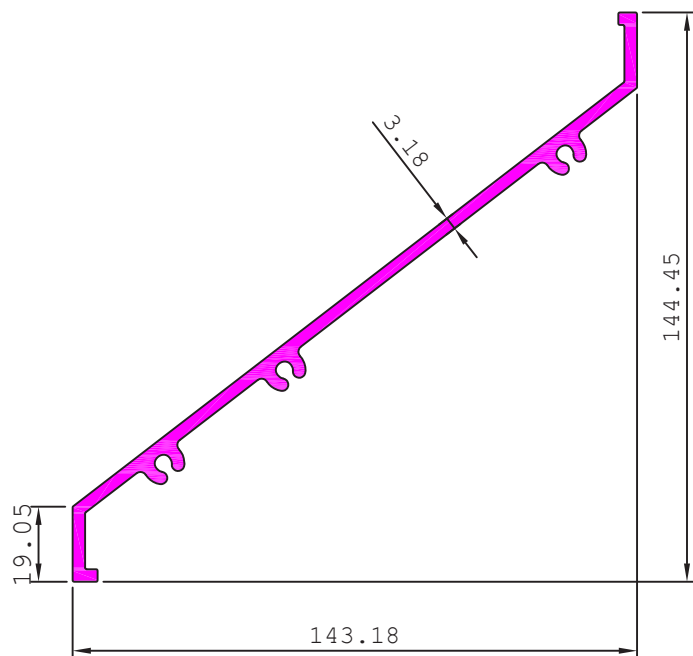

22873

0.983 kg/m

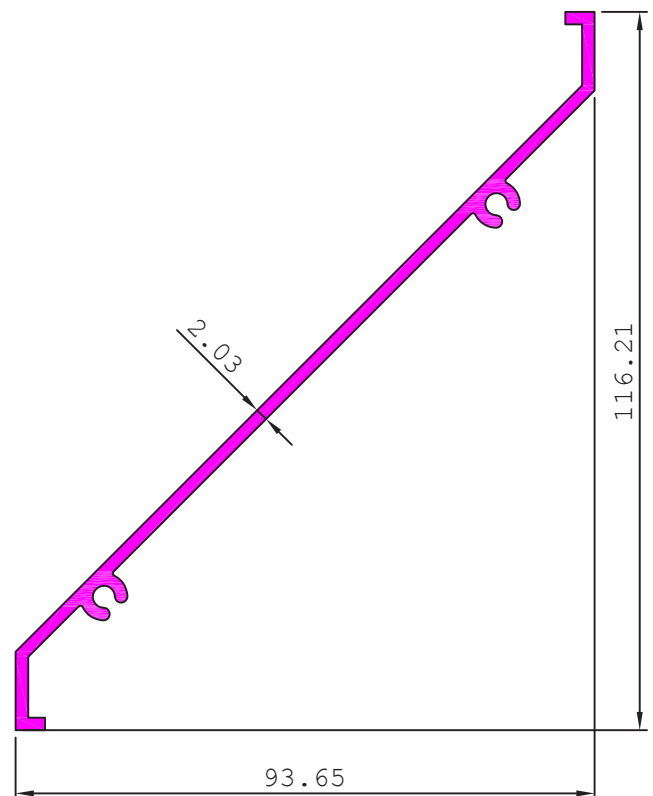

S6387

0.565 kg/m

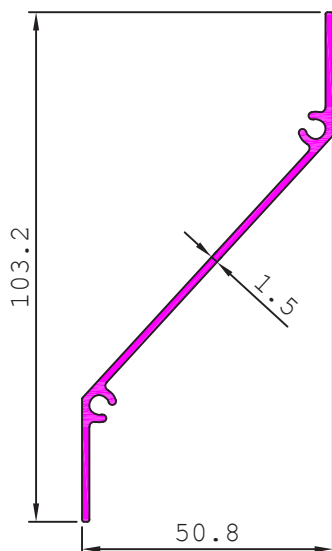

LOUVRE SECTION

S6374

1.582 kg/m

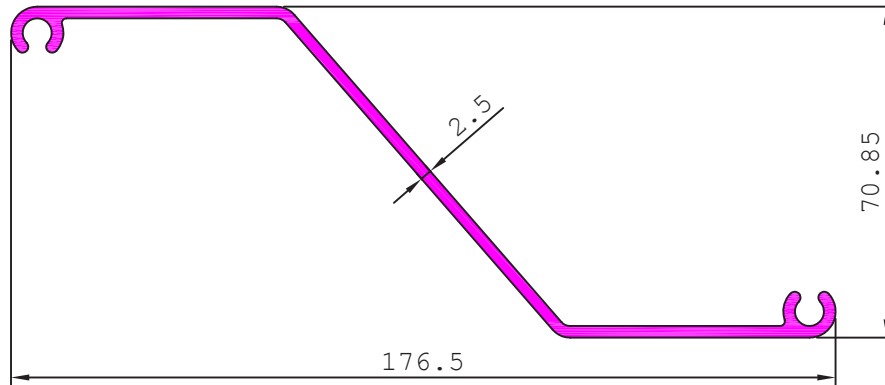

S6381

0.805 kg/m

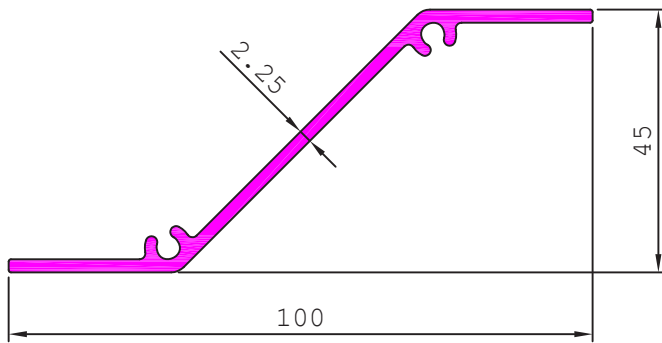

LOUVRE SECTION

21240

3.228 kg/m

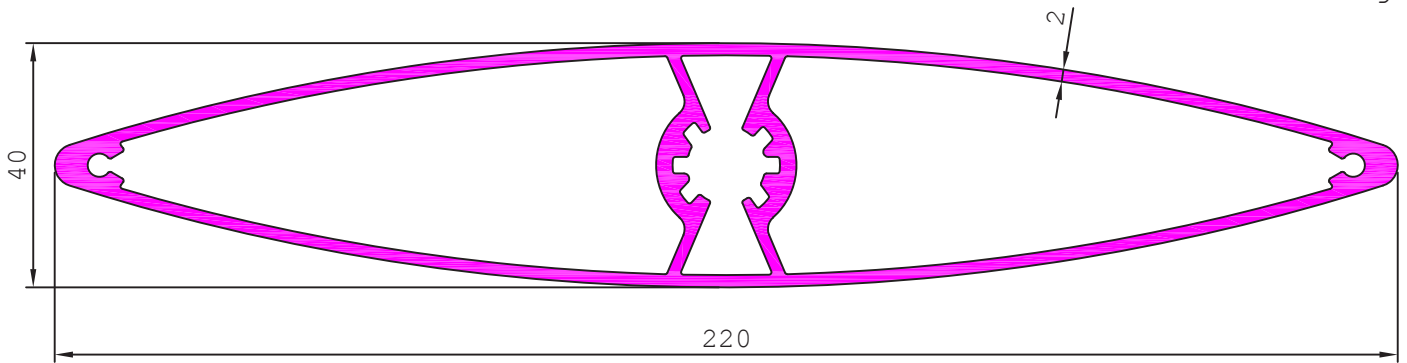

21333

1.086 kg/m

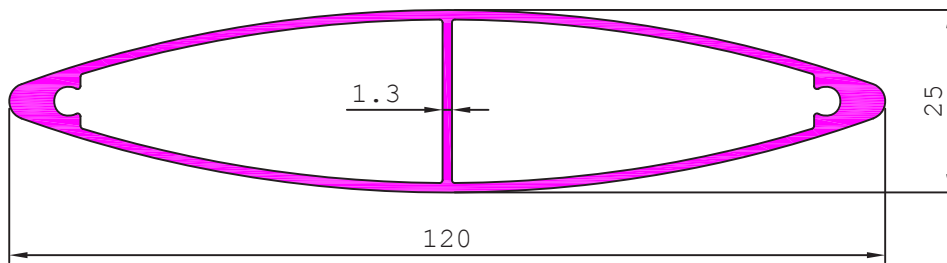

21468

0.843 kg/m

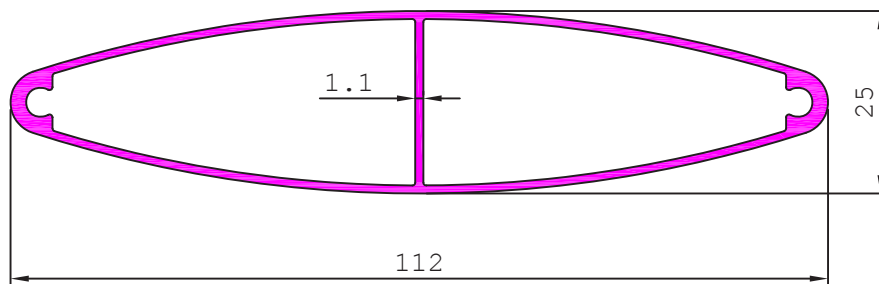

21450

0.678 kg/m

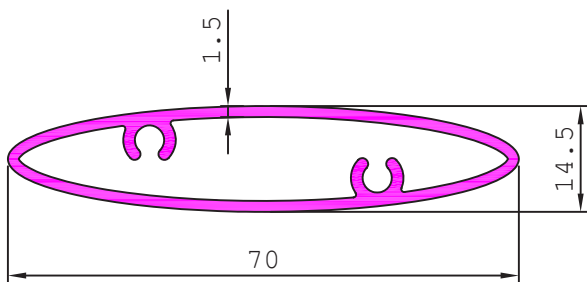

28802

0.706 kg/m

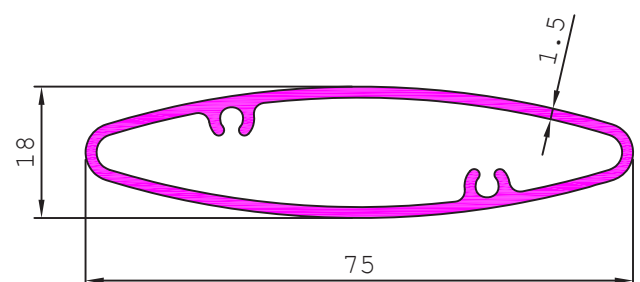

LOUVRE SECTION

21652

2.740 kg/m

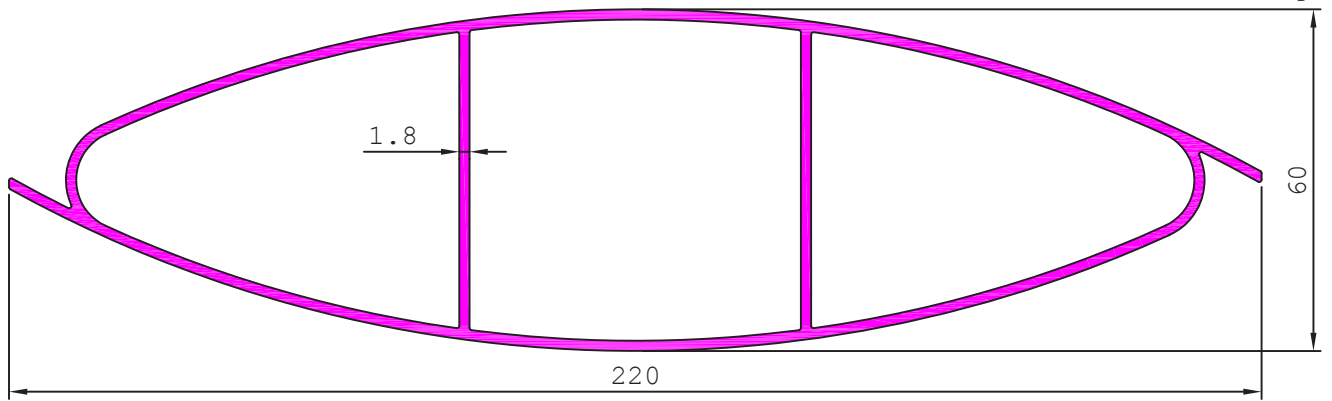

21637

2.038 kg/m

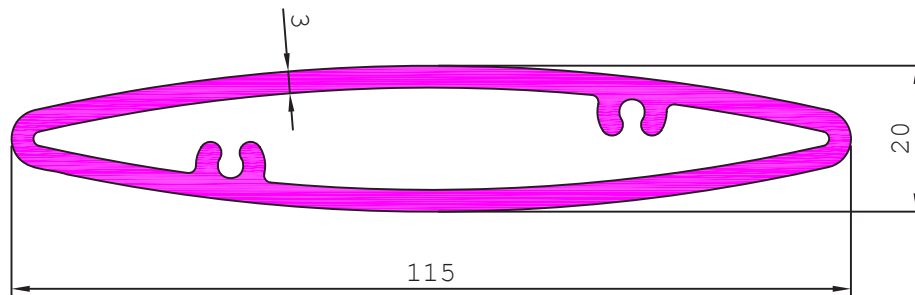

S4669

0.954 kg/m

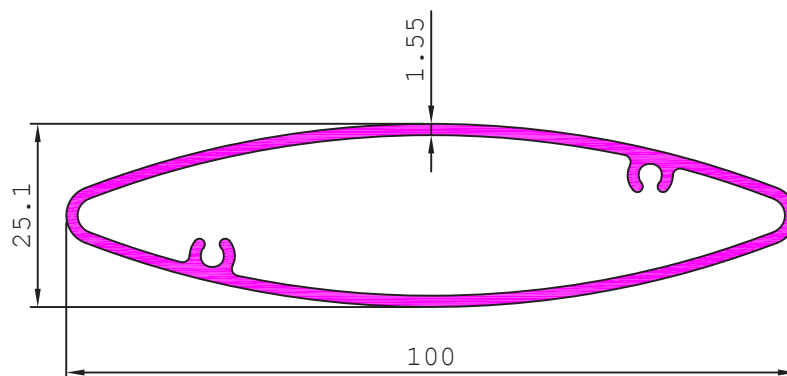

28803

1.573 kg/m

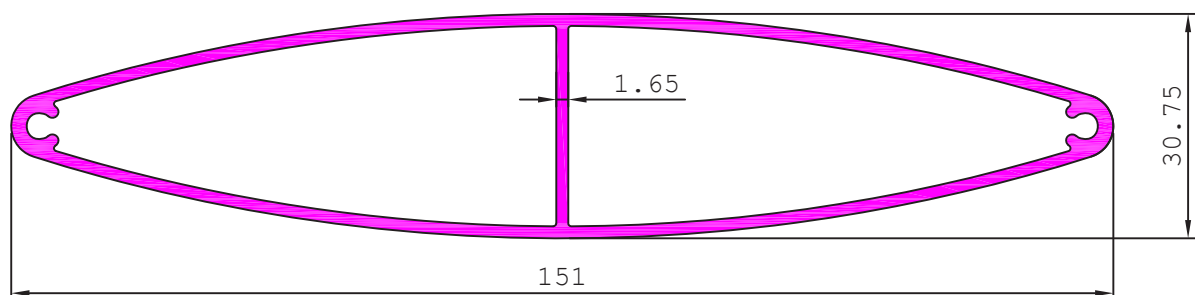

LOUVRE SECTION

22560

3.266 kg/m

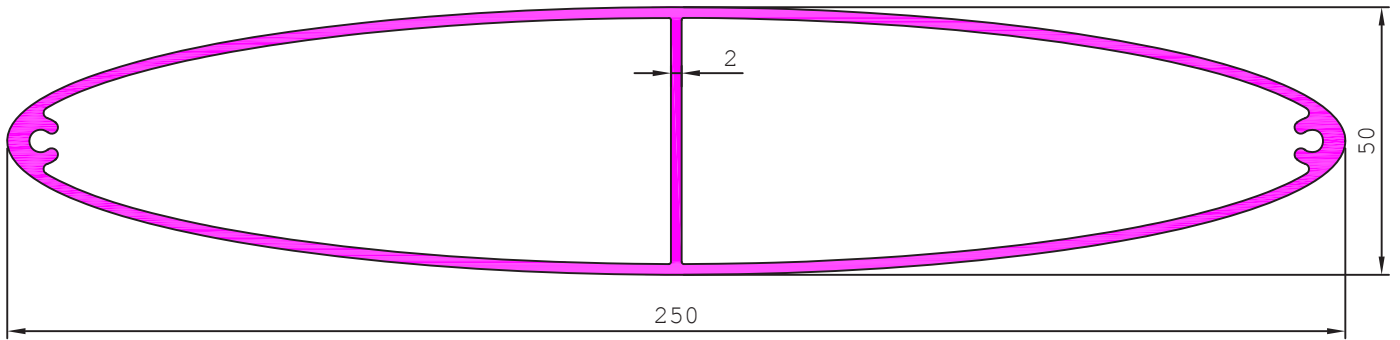

29164

2.511 kg/m

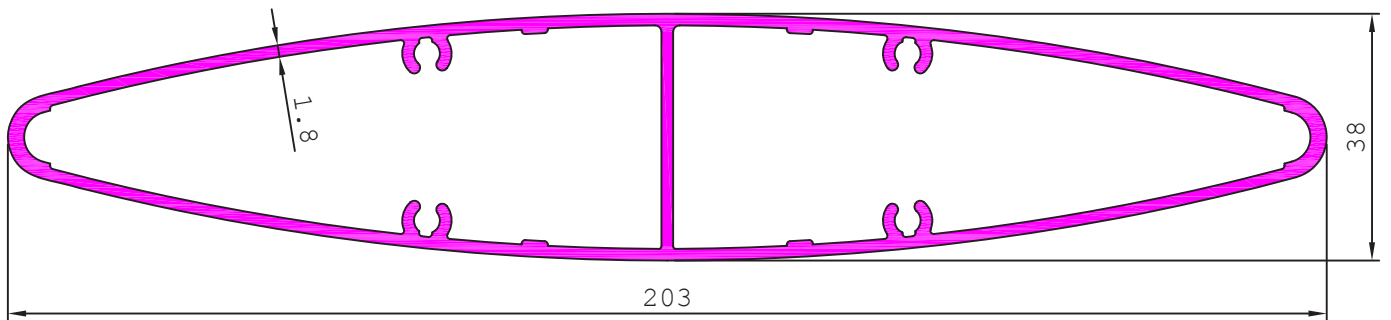

29180

3.646 kg/m

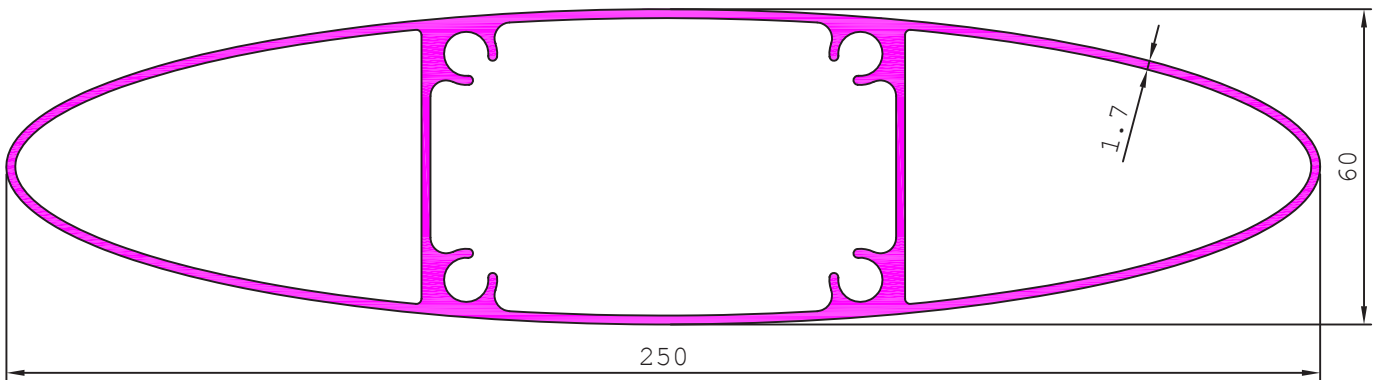

21753

5.576 kg/m

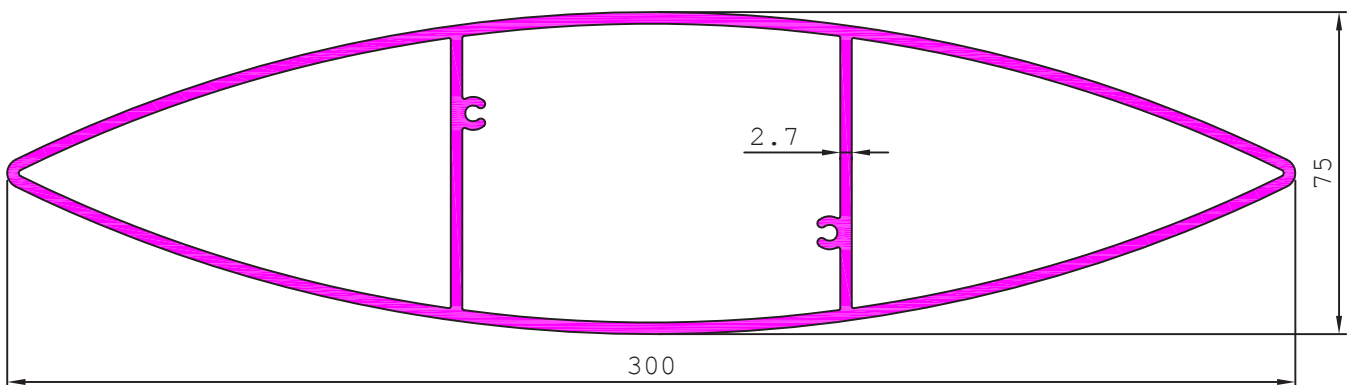

LOUVRE SECTION

S5976

5.293 kg/m

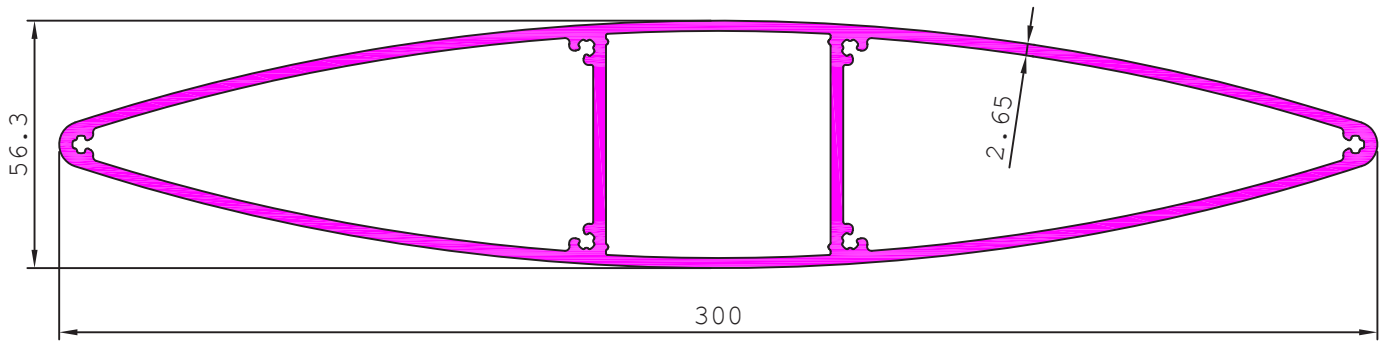

21834

5.199 kg/m

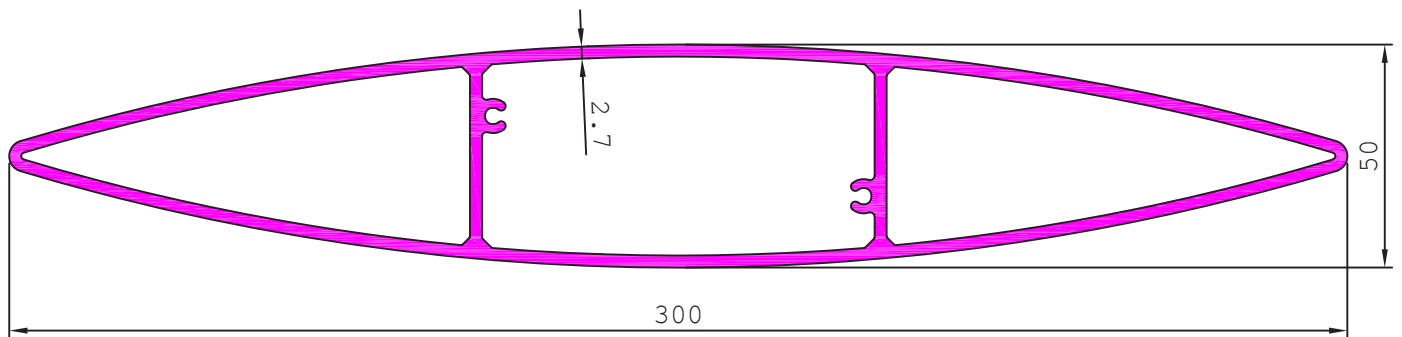

29332

6.336 kg/m

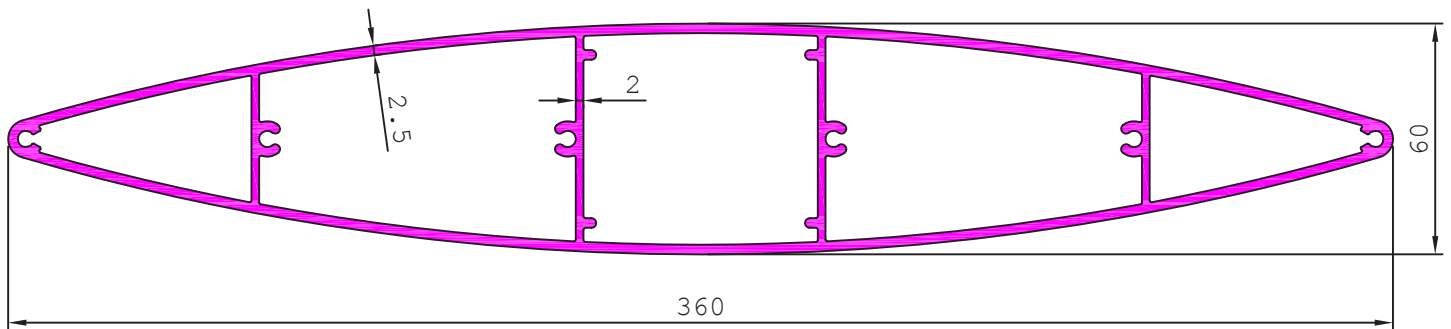

21689

6.093 kg/m

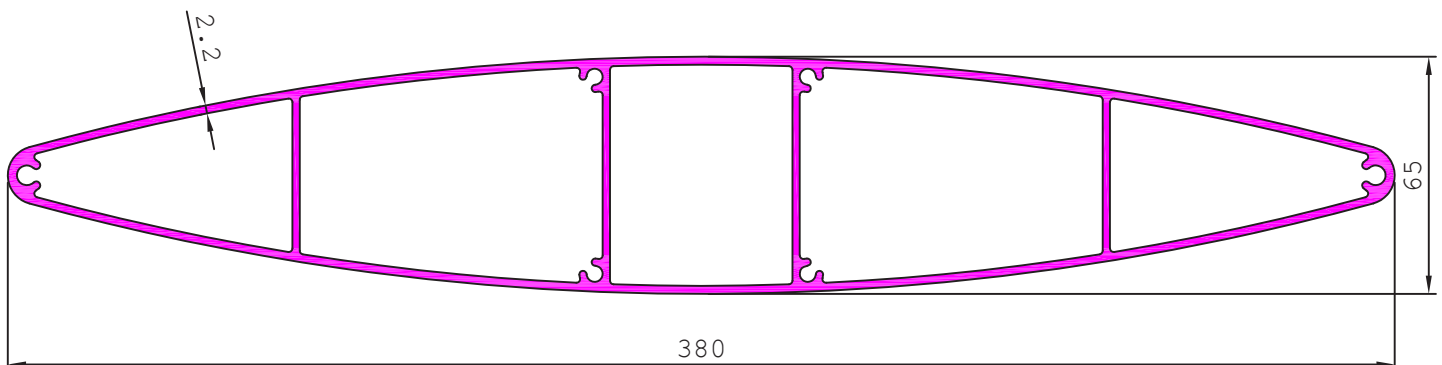

LOUVRE SECTION

21776

6.961 kg/m

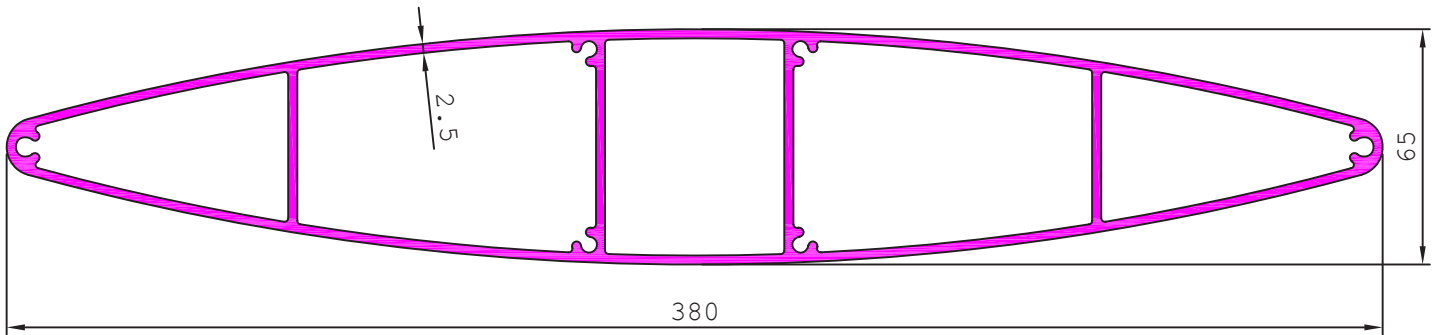

21409

1.547 kg/m

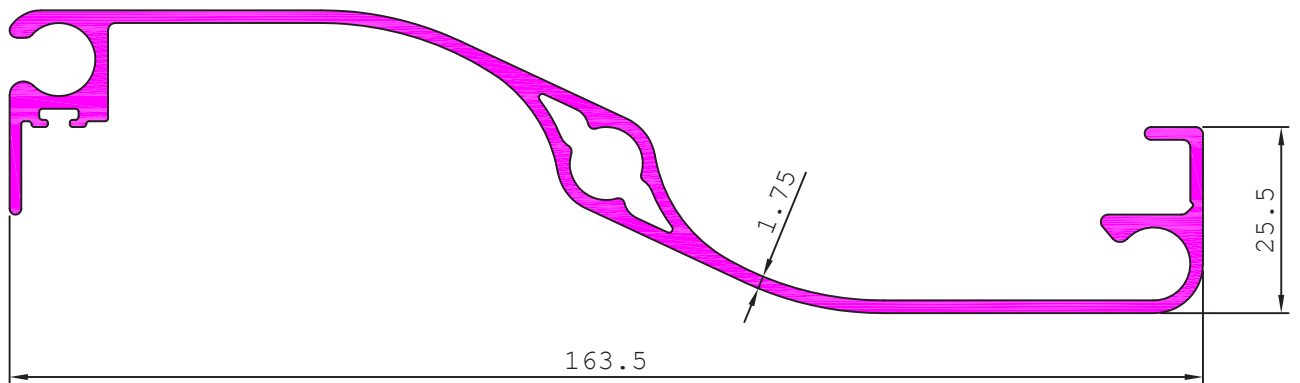

22852

1.379 kg/m

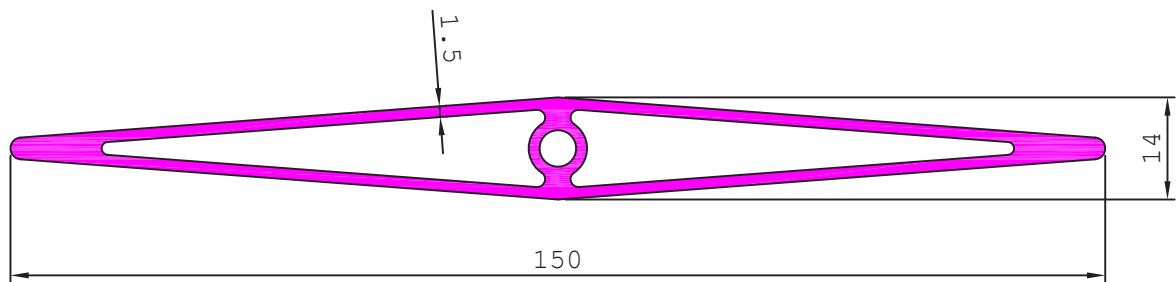

S6435

0.693 kg/m

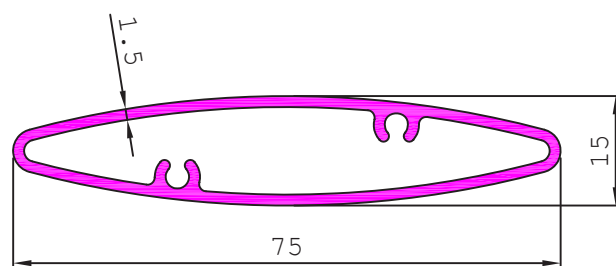

LOUVRE SECTION

21408

3.680 kg/m

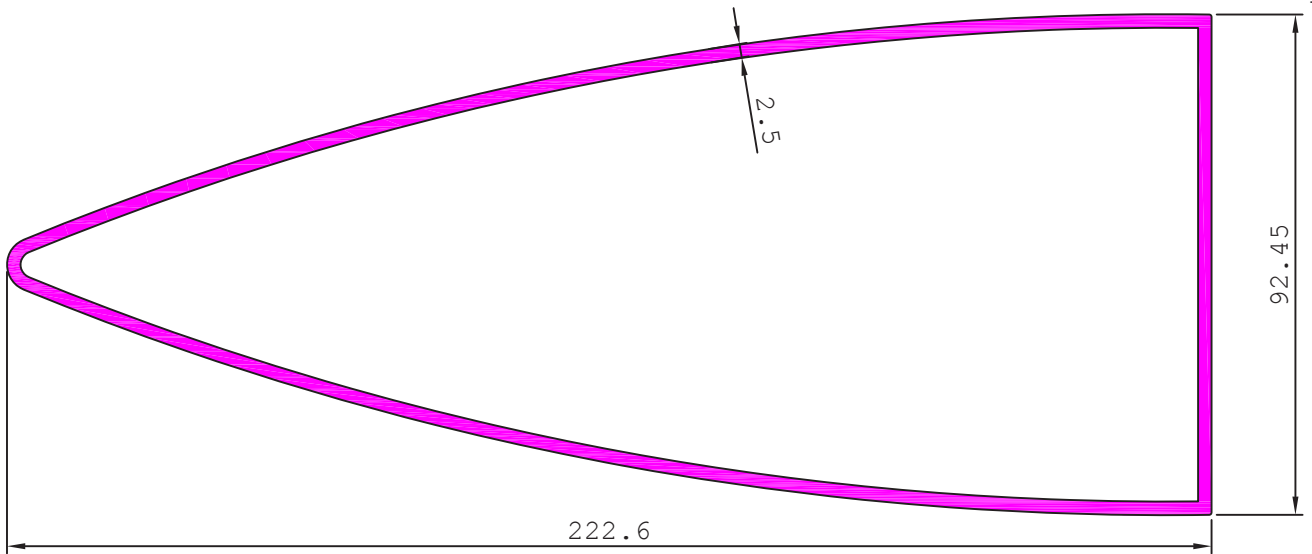

29404

3.048 kg/m

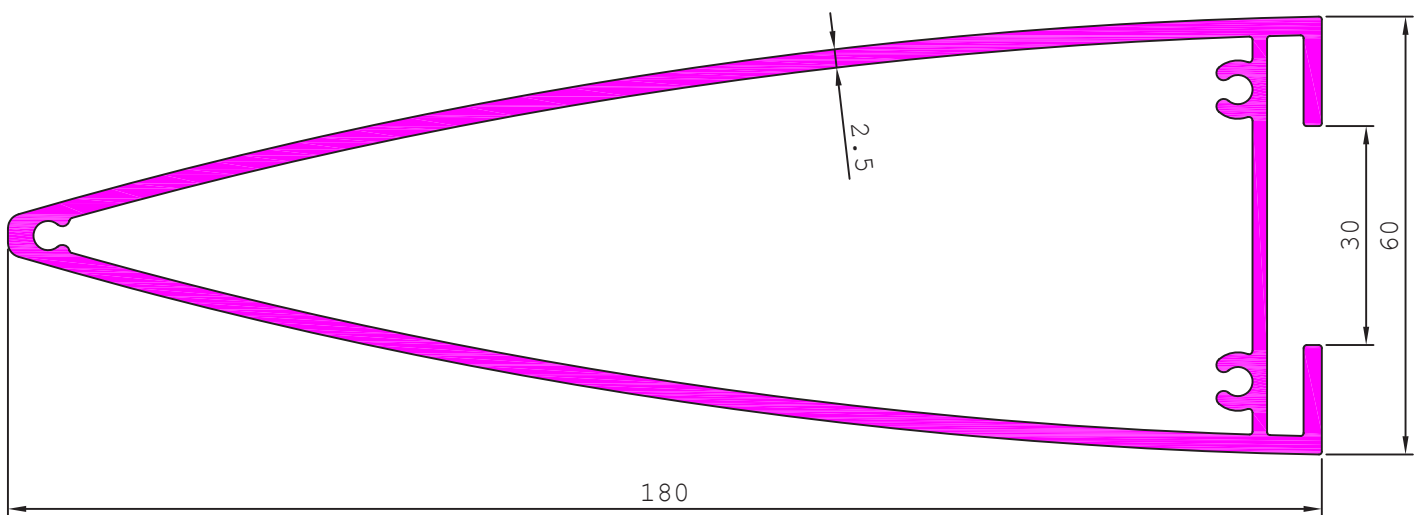

29328

2.477 kg/m

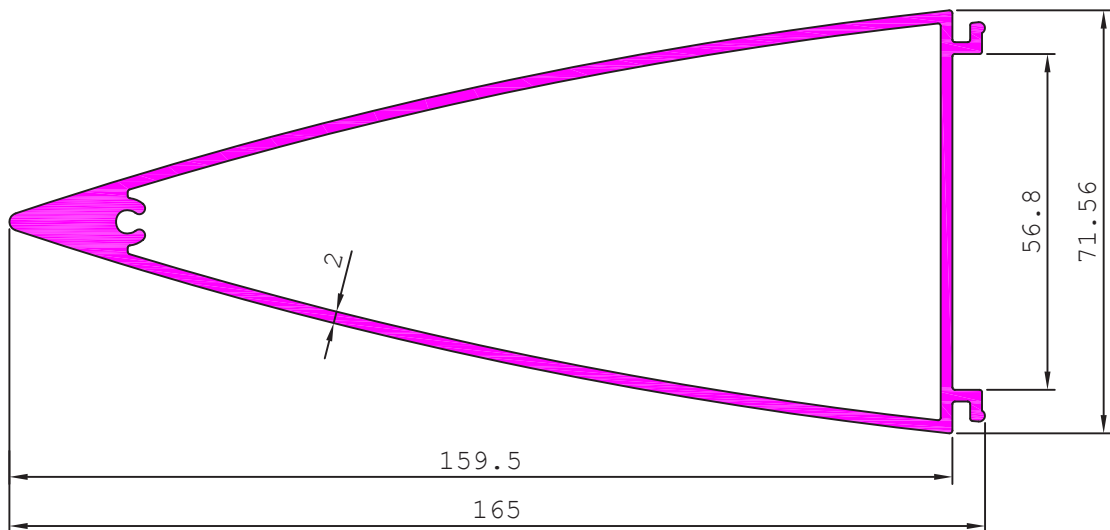

LOUVRE SECTION

S5599

1.811 kg/m

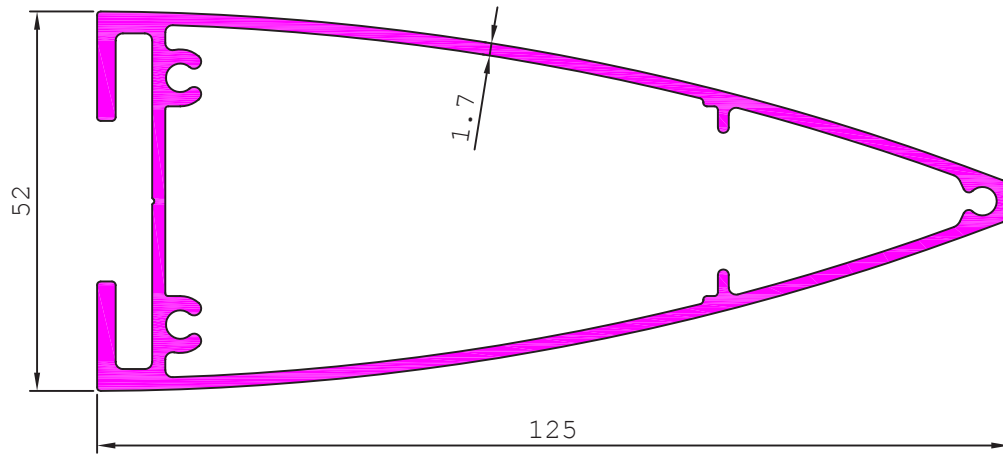

21595

5.979 kg/m

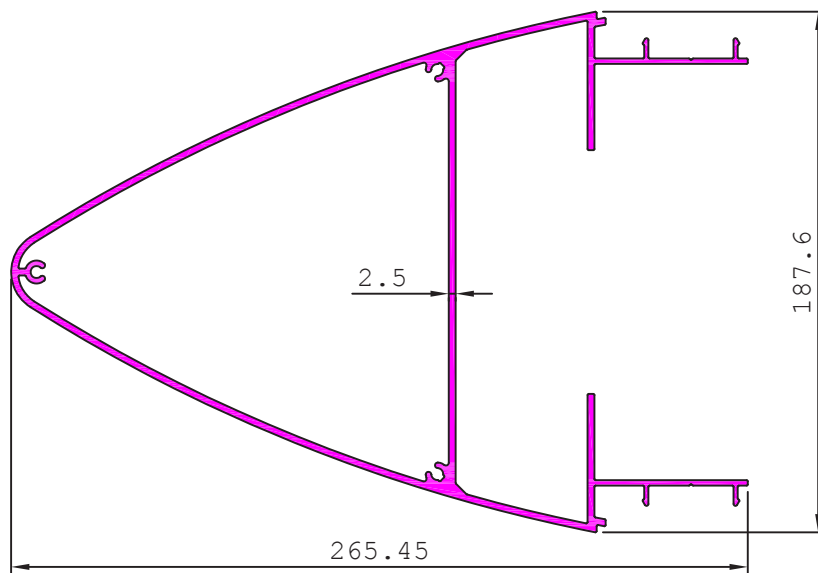

35993

1.109 kg/m

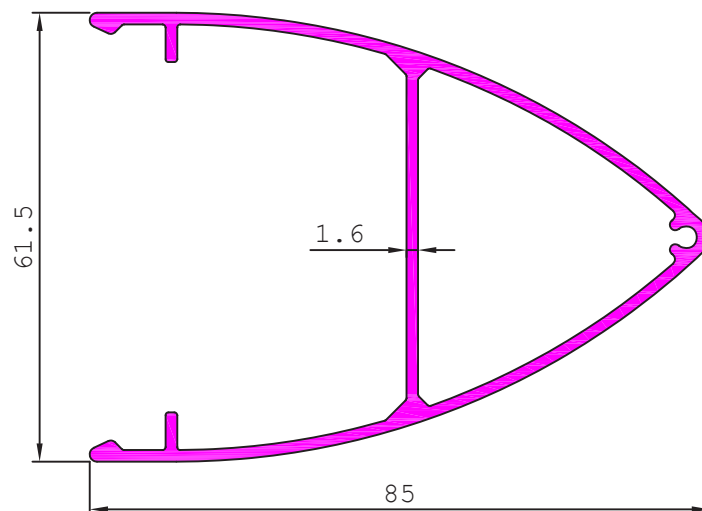

LOUVRE SECTION

S5401

4.339 kg/m

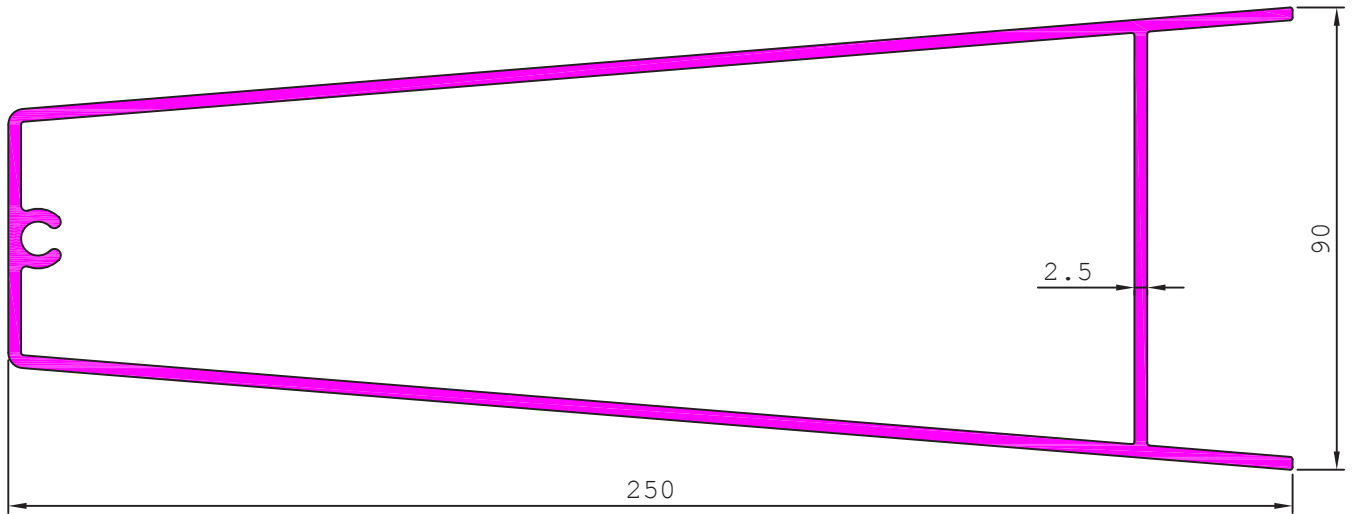

21734

1.492 kg/m

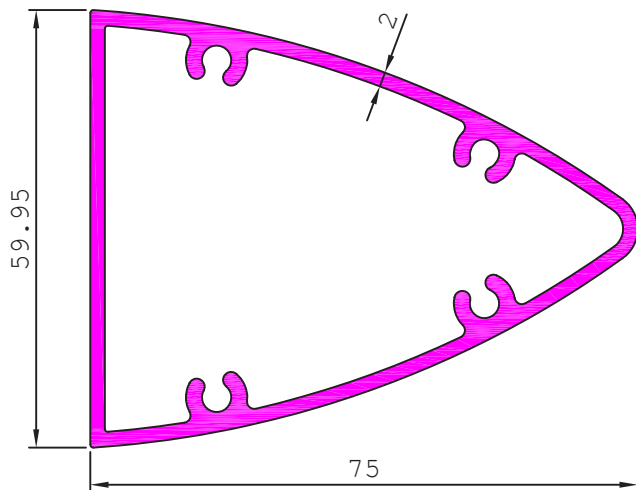

21741

0.532 kg/m

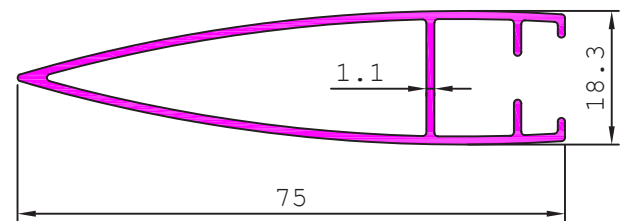

21828

1.001 kg/m

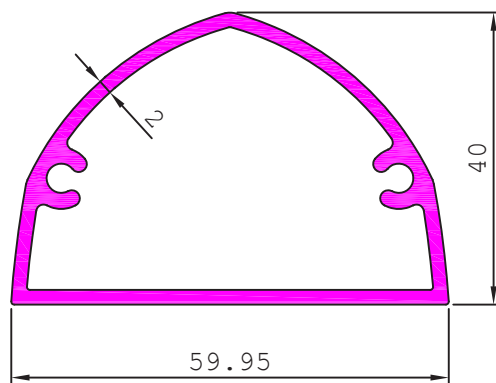

21793

0.893 kg/m

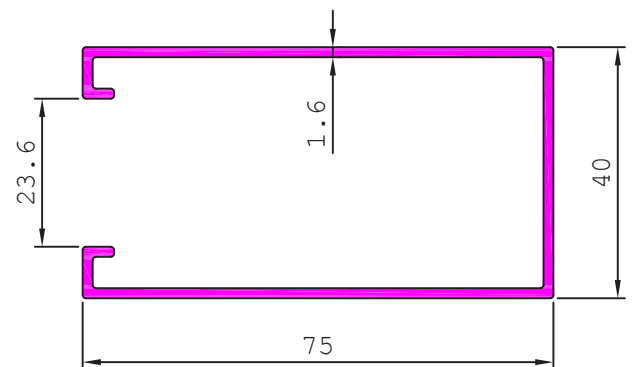

LOUVRE SECTION

21835

3.334 kg/m

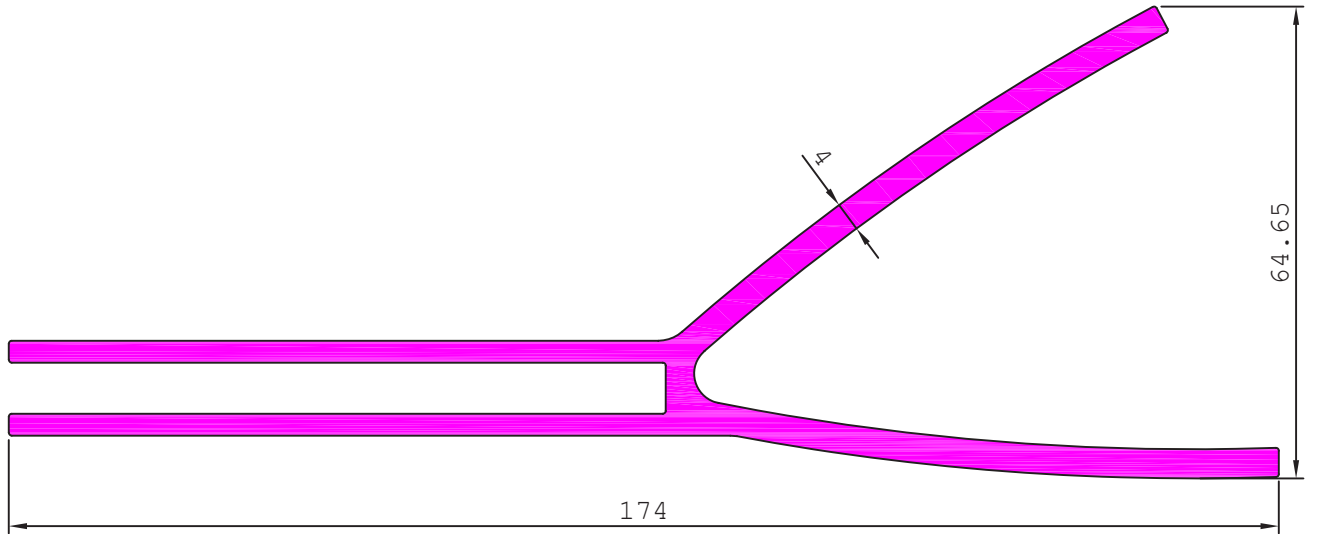

21639

0.854 kg/m

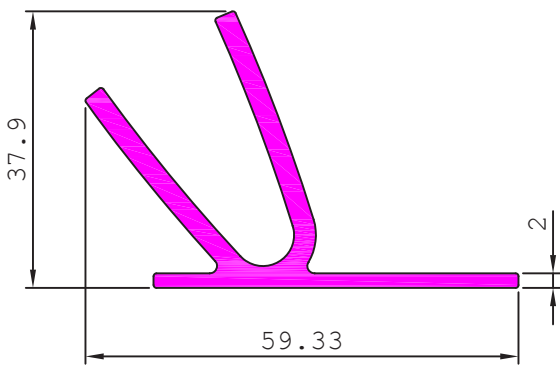

21719

1.048 kg/m

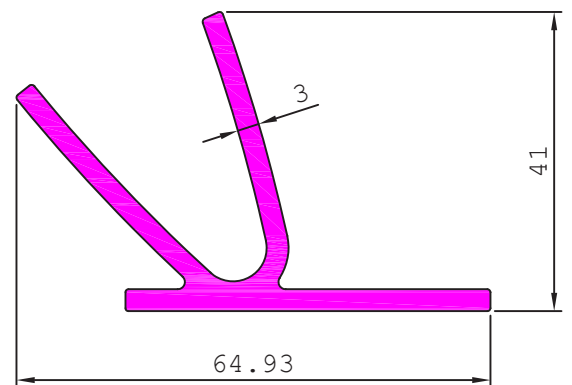

21720

1.129 kg/m

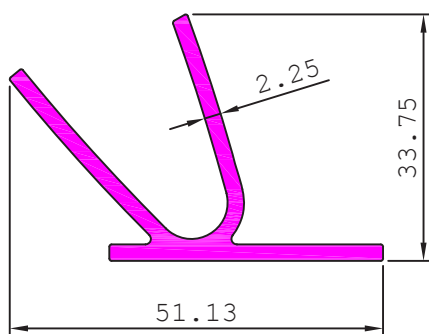

21421

0.728 kg/m

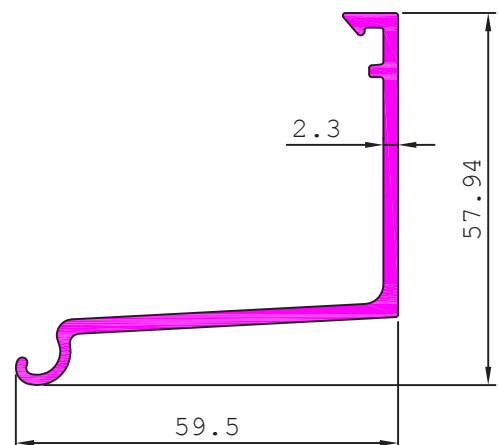

LOUVRE SECTION

21238

0.506 kg/m

21420

0.947 kg/m

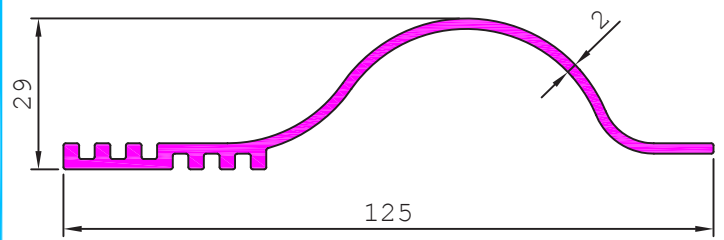
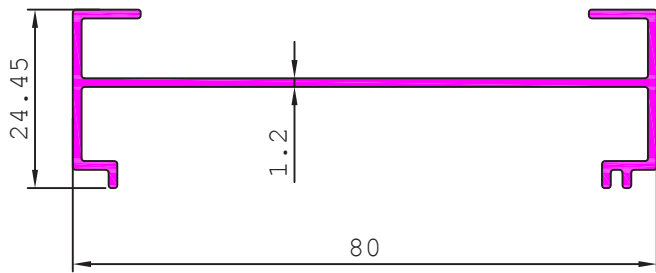

21712

1.267 kg/m

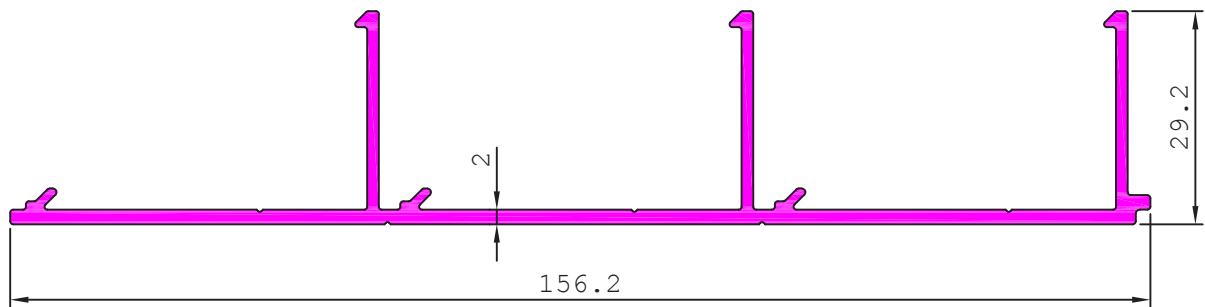

S4313

1.992 kg/m

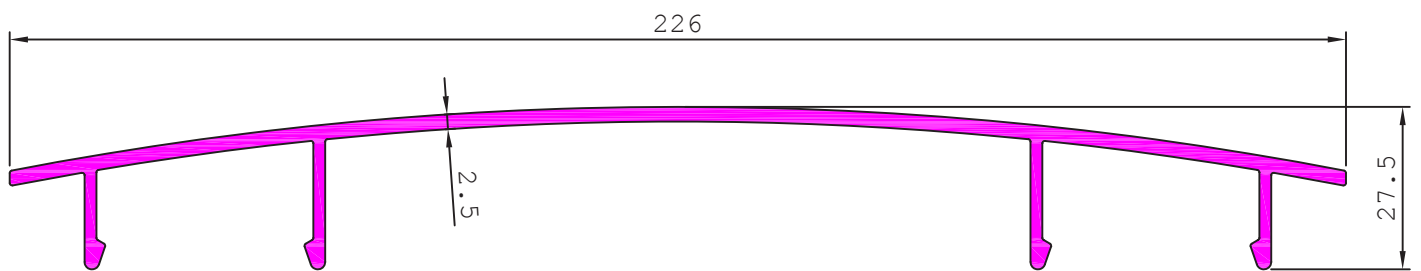

28973

0.462 kg/m

28974

0.426 kg/m

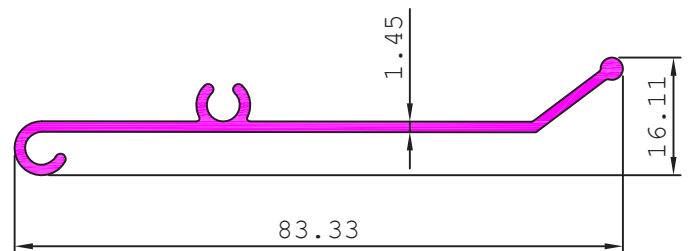
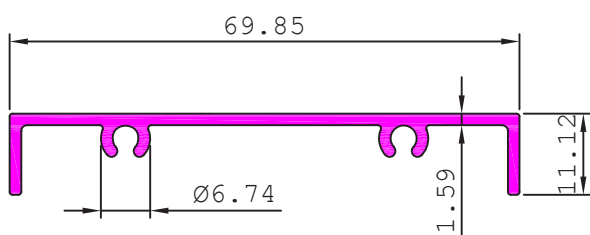

LOUVRE SECTION

S5439

0.371 kg/m

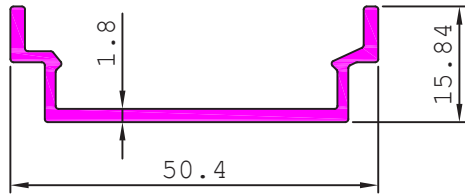

MATCHING WITH 29129

29129

1.091 kg/m

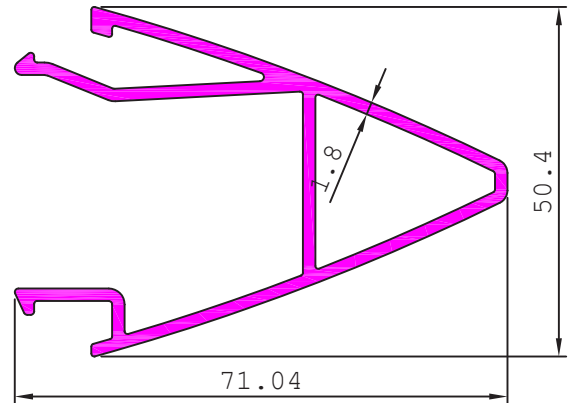

29330

3.243 kg/m

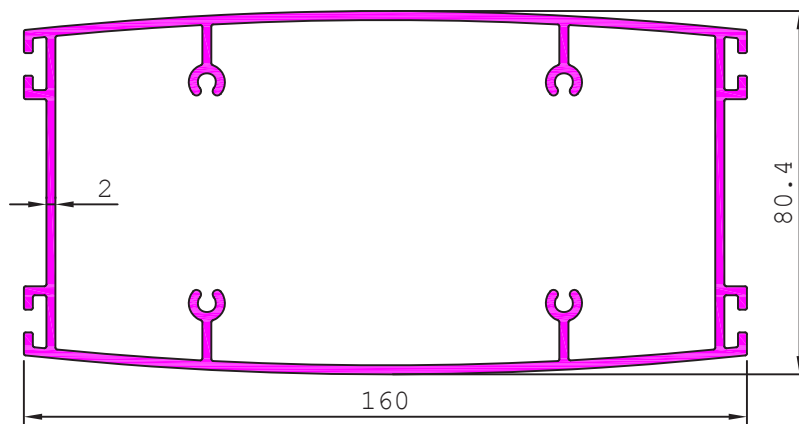

LOUVRE SECTION

S6079

2.540 kg/m

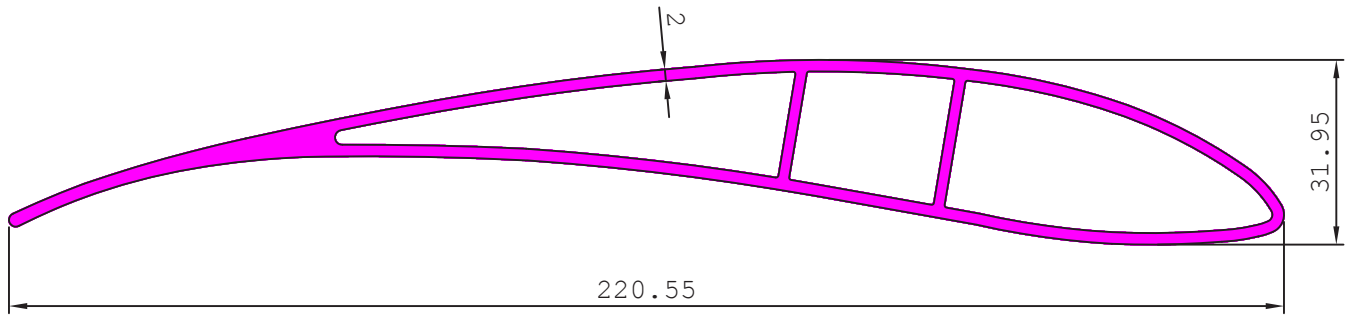

21802

2.652 kg/m

